

ROTARY VANE PUMPS

RE 9

RZ 9

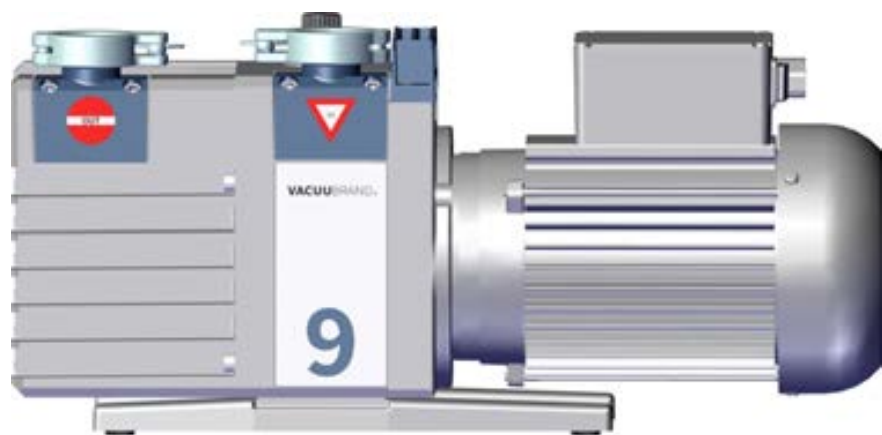

Instructions for repair



Original instructions Keep for further use!

This manual is only to be used and distributed in its complete and original form. It is strictly the user's responsibility to carefully check the validity of this manual with respect to the product.

Manufacturer:

VACUUBRAND GMBH + CO KG
Alfred-Zippe-Str. 4
97877 Wertheim
GERMANY

Phone:

Head office +49 9342 808-0
Sales +49 9342 808-5550
Service +49 9342 808-5660

Fax: +49 9342 808-5555

Email: info@vacuubrand.com

Web: www.vacuubrand.com

*Thank you for purchasing this product from **VACUUBRAND GMBH + CO KG**. You have chosen a modern and technically high quality product.*

CONTENTS

1	Introduction	5
1.1	User information.....	5
1.2	About this document.....	6
1.2.1	Symbols and icons.....	6
1.2.2	Display conventions.....	7
2	Safety instructions	8
2.1	Target groups.....	8
2.2	Safety precautions.....	8
2.2.1	Personal responsibility.....	9
2.2.2	Eliminate sources of danger.....	9
2.3	Environmental protection.....	10
3	Notes concerning repair	11
3.1	General notes.....	12
3.2	Prior to maintenance and repair.....	13
3.3	After maintenance and repair.....	13
3.4	Cleaning the components.....	14
3.5	Notes on pressing in shaft seals.....	14
4	Maintenance	15
4.1	Tools.....	16
4.2	Replacing the removable sleeve.....	17
4.3	Maintenance RE 9.....	24
4.4	Maintenance RZ 9.....	50
5	Press-in mandrels	79
5.1	Selection of the press-in mandrel.....	79
5.2	Mandrel 3.....	80
6	Pull-off plate	81
7	Exploded drawing RE 9	82
8	Exploded drawing RZ 9	83
9	Spare parts	84
10	Service	85

1 Introduction

Make yourself familiar with the device.

Use this manual as reference for the repair of your device.

1.1 User information

Safety

Instructions for use
and safety



- Read this manual thoroughly and completely before starting repair. Keep this manual in an easily accessible location.
- Observe all safety instructions provided also in the instructions for use of the device and in the document “Safety instructions for vacuum equipment”! The document ”Safety information for vacuum equipment - Sicherheitshinweise für Vakuumgeräte” is part of the instructions for use!
- In addition to this manual, adhere to any relevant local accident prevention regulations and comply with industrial safety regulations.

General

General
information

- The illustrations in this manual are provided as examples. They are intended to aid in your understanding.
- **VACUUBRAND GMBH + CO KG** reserves the right to modify or change the product design and/or technical specifications at any time without advanced notice.

Copyright

Copyright ©

The content of these instructions is protected by copyright. Only copies for internal use are allowed, e. g., for professional training.

© **VACUUBRAND GMBH + CO KG**

Contact

Contact us

- Please ask for replacement in case of incomplete instructions for use. Alternatively, you can download instructions for use on our web page: www.vacuubrand.com.
- Contact us regarding any questions about this product, if you need further information, or to provide us with feedback.
- When contacting our Customer Service Department, please be sure to have the data from the rating plate.

1.2 About this document

1.2.1 Symbols and icons

Safety symbols



Warning symbol.



Use hand protection



Use eye protection

Additional icons



Refers to content of other documents.

Additional notes

Convention for additional notes

IMPORTANT! Information or specific use recommendation, which must be observed.





- ⇒ Helpful tips
- ⇒ Additional information

1.2.2 Display conventions

Warning levels

Convention for warnings

	DANGER
	<p>Indicates an imminent hazardous situation.</p> <p>Disregarding the situation will result in serious and even fatal injury or death.</p> <p>⇒ Take appropriate action to avoid dangerous situation!</p>
	WARNING
	<p>Indicates a potentially hazardous situation.</p> <p>Disregarding the situation could result in serious, even fatal injury or massive damage to property.</p> <p>⇒ Observe instruction to avoid dangerous situation!</p>
	CAUTION
	<p>Indicates a potentially hazardous situation.</p> <p>Disregarding the situation could result in slight or minor injury or damage to property.</p> <p>⇒ Observe instruction to avoid dangerous situation!</p>

Individual step (single step)

Design of steps

- ⇒ Do the described step.
- Result of action.

Multiple steps

Graphic

1. First step,
 2. next step.
- Result of action.

Follow steps in the described order.

2 Safety instructions

All safety instructions must be observed by all individuals working with the products described here.

Maintenance and repair are intended to ensure the functional condition or the return to function in the event of a failure.

Repair includes troubleshooting and remedy.

2.1 Target groups

Qualified personnel

Maintenance and repair may only be carried out by suitably qualified personnel.

The qualified personnel has to carry out the necessary work in accordance with the statutory requirements (e.g., safety at work, environmental protection).

The function and safety of the device must not be impaired.

The qualified personnel must be adequately informed of the risk involved in their intervention.

The qualified personnel must be adequately informed of potentially hazardous substances in the device.

2.2 Safety precautions

Quality standards and safety

Products of **VACUUBRAND GMBH + CO KG** are subject to high quality tests with goals for safety and operation. Prior to delivery each product has been tested thoroughly.

Nevertheless, during operation unforeseen dangerous situations may occur which may lead to injuries or damage of property. Therefore observe the following chapter and take the appropriate safety precautions.

2.2.1 Personal responsibility

Qualification and
personal
responsibility

Ensure that only authorized and skilled personnel works with the equipment. This is particularly important with regard to troubleshooting and remedy.

- ⇒ Carefully read these instructions for repair before starting work.
- ⇒ Replace wear parts regularly.
- ⇒ Never operate a defective or damaged device.
- ⇒ Personal safety has top priority!
- ⇒ Always be conscious of safety.
- ⇒ Observe the owner's directives at work, the national accident prevention regulations and occupational safety provisions.

2.2.2 Eliminate sources of danger

Use only in proper
working condition

Only use the vacuum system when it is in proper working condition.

- ⇒ Carry out maintenance and repair outside any hazardous area, e.g., outside potential explosive atmospheres.

Safe work

The owner must determine additional protective measures to ensure safe personal protection if work has to be carried out inside a hazardous area.

- ⇒ Observe the operating instructions of the owner.
- ⇒ Switch off the device prior to maintenance and repair.
- ⇒ Secure the device against restarting.

Dangerous voltage

Parts may carry dangerous voltages for some minutes even when the device is switched off.

To avoid fatal injuries do not carry out any work during this period.

- ⇒ Mark activities at the device appropriately, e. g. using an instruction plate. Ensure that the instruction plate is in place also during temporary interruption.
- ⇒ Afterwards restore the protective equipment immediately, if you have deactivated safety functions and protective equipment due to maintenance or repair work.
- ⇒ Replace defective components by new components with the same order number or by equivalent components.
- ⇒ Prevent the entry of liquids or dust into the device.

Health hazards

The device may be contaminated with substances dangerous to health or otherwise dangerous substances.

- ⇒ Decontaminate or clean the device prior to maintenance or repair, if necessary.
- ⇒ Observe safety and protective measures when working with hazardous substances.
- ⇒ Ask regularly for current material safety data sheets.
- ⇒ Observe the owner's hazardous substances operating instructions.
- ⇒ Wear your personal protective equipment.

2.3 Environmental protection

Observe environmental regulation

Observe the national and international environmental regulations for disposal of your product as well as spare parts. This applies particularly to all components that are contaminated with hazardous substances.

Dispose of chemicals, e. g., cleaning agent, according to regulations.

Scrapping and waste disposal

Proper disposal

As a result of increased environmental awareness and more stringent general requirements imposed by environmental legislation, a proper scrapping and disposal of no longer usable or non-reparable equipment is required.



If you wish to dispose of a VACUUBRAND electrical or electronic device, this must be done separately from unsorted municipal waste. This is indicated by the symbol of the crossed-out wheeled bin (see illustration).

VACUUBRAND offers to dispose of your device with this symbol for you.

To do this, please contact our service team.





Please note the data privacy rules and delete all data on the device.

service@vacuubrand.com

Tel.: +49 9342 808 5660

3 Notes concerning repair

IMPORTANT! Replace defective parts in any case.

	<p>WARNING</p> <p>Risk of injury due to a disassembled device.</p> <p>Operating a disassembled device may lead to personal injury.</p> <ul style="list-style-type: none">⇒ Never operate an opened or disassembled device.⇒ Ensure that a disassembled device never starts unintentionally.
	<p>WARNING</p> <p>Damage due to overaged motor capacitors.</p> <p>If an old motor capacitor fails, the capacitor may get hot. It may even melt or emit a flame.</p> <ul style="list-style-type: none">⇒ Check every capacitor regularly by measuring its capacity and estimating its operation time. Exchange old capacitors early enough to prevent a failure.⇒ The capacitors have to be replaced by a qualified electrician.
	<p>CAUTION</p> <p>Damage due to defective wear parts.</p> <p>Defective wear parts may lead to failure of the device.</p> <ul style="list-style-type: none">⇒ Wear parts have to be replaced in time.
	<p>DANGER</p> <p>Danger of electric shock.</p> <p>Danger of electric shock due to improperly executed repairs.</p> <ul style="list-style-type: none">⇒ Check the electrical safety of the device according to IEC 61010 and national regulations after repair.⇒ Check the protective conductor resistance.⇒ Check the insulation resistance.⇒ Carry out a high voltage test.⇒ Check the leakage current according to DIN EN 50678:2021 (EN 50678:2020) and national regulations.

3.1 General notes

Oils

- ⇒ Comply with all relevant laws and regulations for the handling, storage and disposal of oils.
- ⇒ Use only oil of the recommended type, see instructions for use of the pump. Other oils or operating fluids may damage the pump or cause hazards.
- ⇒ Prevent oil from entering sewers or bodies of water.
- ⇒ Do not spill oil. Clean up spilled oil immediately. Spilled oil poses a slip hazard!
- ⇒ Prevent the release of hazardous, toxic, explosive, corrosive, harmful or environmentally hazardous fluids, gases or vapors as well as oil vapors, e.g. by using suitable laboratory equipment with fume hood and ventilation control.
- ⇒ Ensure that the installation site of the vacuum pump is well ventilated.
- ⇒ Do not breathe in oil vapors.
- ⇒ Use your personal protective equipment when working with pump oils to avoid skin contact and possible irritation.
- ⇒ Wet all sliding surfaces with the vacuum pump oil you are using to operate the pump before reassembly.



Sealing rings

- ⇒ Use new sealing rings / O-rings.

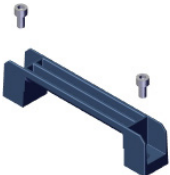

- ⇒ When replacing the handle, assemble the screws using Omnifit® 50M locking adhesive.

3.2 Prior to maintenance and repair

Preparation

Genuine spare parts

⇒ Use only genuine spare parts and accessories.

When using components of other manufacturers the safety and performance of the equipment as well as the electromagnetic compatibility of the equipment might be reduced.

Possibly the CE mark or the C/US conformity (see rating plate) becomes void if not using genuine spare parts.

⇒ Check that the required tools and parts are available and of the correct type before you start your work.

⇒ Check the operating sequence mentally on feasibility, safety requirements and consequences on safety and function of the equipment using the exploded drawing, spare parts lists and, if necessary, the electrical circuit diagrams.

Separate from
mains

⇒ Separate the device from mains prior to maintenance or repair. Switch off the device and unplug.

⇒ Vent the device.

⇒ Allow the device to cool down.

⇒ Allow the capacitors to discharge.

3.3 After maintenance and repair

Testing

Testing

Check operability and safety after maintenance and repair.

⇒ Check the electrical safety according to IEC 61010 and national regulations after maintenance and repair.

⇒ Check the leakage current according to DIN EN 50678:2021 (EN 50678:2020) and national regulations.



In case of problems return the device to the factory for inspection or repair if necessary.

⇒ Observe section „Return“.

3.4 Cleaning the components



- ⇒ Dispose of used oil and solvents, taking into account any contamination from pumped-off substances / chemicals, in accordance with the relevant regulations.
- ⇒ Avoid damage to running and sealing surfaces.
- ⇒ Use clean oil and a lint-free cloth to clean sealing rings. Replace defective sealing rings.
- ⇒ Check the silencer nozzle for dirt. Clean a dirty silencer nozzle with a wire (diameter 0.2 mm).
- ⇒ Use petroleum ether or technical solvent to clean all other parts. Observe the regulations for handling solvents.
- ⇒ Dry all parts after cleaning.

3.5 Notes on pressing in shaft seals



- ⇒ Shaft seals should only be fitted using a special press-fit mandrel.
- ⇒ When pressing in, pressure must only be applied to the outer ring of the shaft seal.
- ⇒ When pressing in rotary shaft seals using a press-in mandrel, care must be taken to ensure that the mandrel can exit unhindered on the underside of the seal ring.
- ⇒ Recommended set of tools for rotary vane pumps: 22612186

4 Maintenance



Dismantle the separator and the exhaust filter, if present, before servicing.



Check the overpressure valve (accessory) at the oil reservoir during maintenance, if an overpressure valve is installed. Checking the overpressure valve is described in the instructions for use of the overpressure valve.



In the event of oil leakage from the pump (oil dripping from the bottom of the housing), it is often sufficient to replace only the replacement sleeve or the oil reservoir seal. The pump oil does not have to be drained for this.

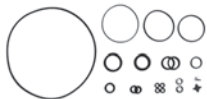

During maintenance, all seals / O-rings should always be replaced.

Maintenance kit RE 8/9 - RZ 9/16: 20649988

4.1 Tools



Tool kit 22612186

- Puller sleeve for coupling
- Press-in mandrel 3 for shaft seal
- Press-in mandrel 4 for shaft seal
- Press-in mandrel 7 for shaft seal
- Puller for coupling with cylinder screws and wing screw
- Screwdriver M4 negative
- Screwdriver M5 negative

⇒ The tool set contains parts which are not required in individual cases.



Tools

- Allen key SW 2,5/5/6
- Open-end wrench SW 7/17
- Phillips screwdriver size 2
- Screwdriver with flat blade size 1/2/3

4.2 Replacing the removable sleeve

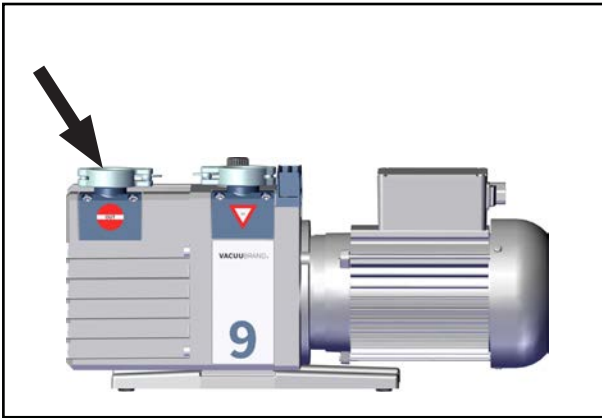

1. Close the pump outlet.



2. Place the pump on the oil reservoir (on the rating plate).



3. Unscrew the motor.



4. Lift off the motor.



5. Remove the cross coupling.

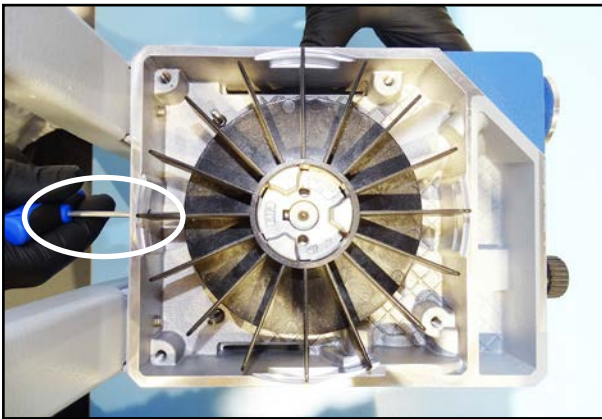

6. Loosen the coupling by turning the grub screw in the coupling (one turn).
⇒ Do not unscrew the grub screw completely.

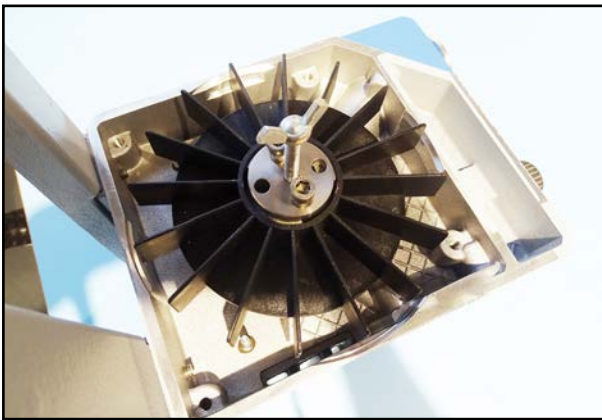

7. Place the pull-off disk on the coupling and insert the wing screw and the two cylinder screws.



8. Screw in the cylinder screws.

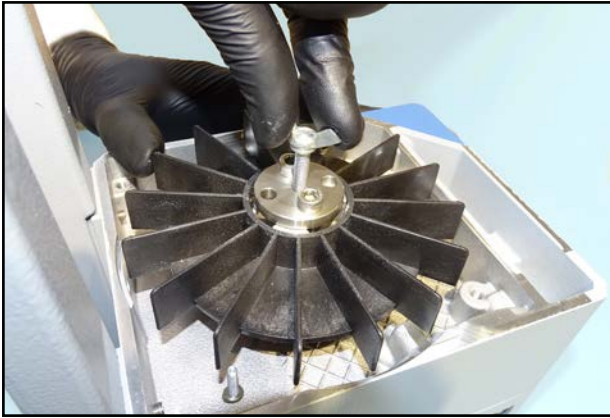

9. Screw in the wing screw until the fan wheel with coupling is released.

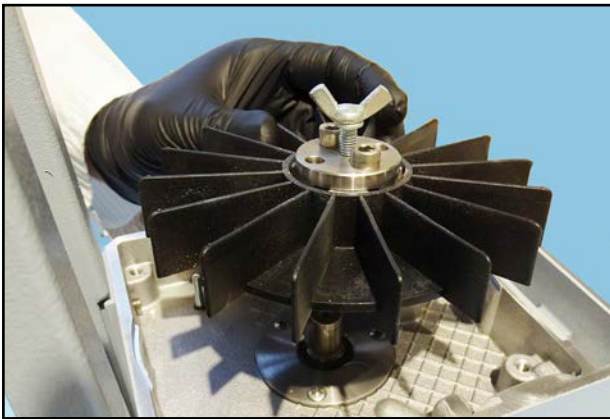

10. Remove the fan wheel with coupling.

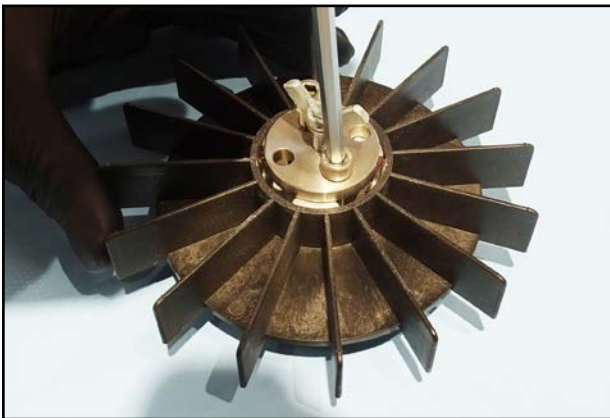

11. Remove the pull-off disk and the screws from the fan wheel.



12. Unscrew the suction felt cover.

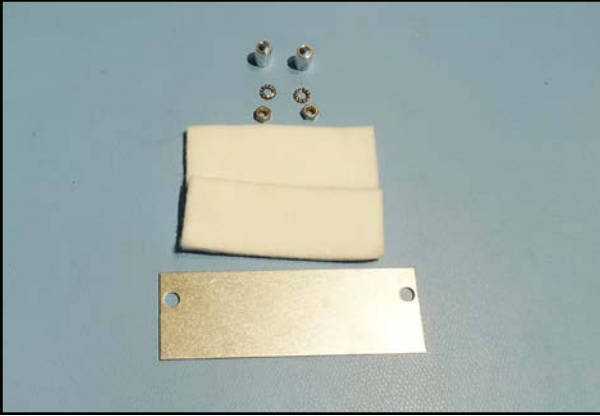

13. Replace the suction felts if they are soaked with oil.



14. Unscrew the removeable sleeve.



15. Lift off the removeable sleeve.

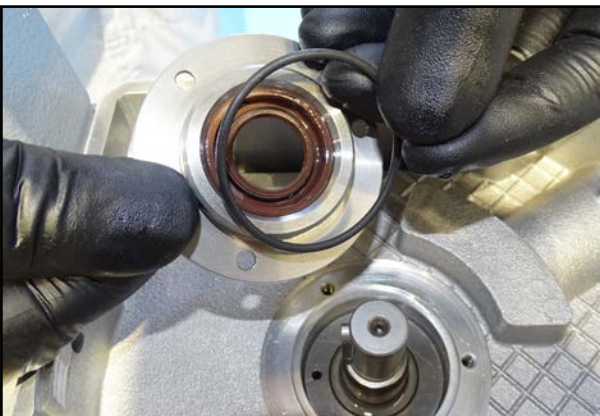

16. Place a new O-ring around the new removeable sleeve.



17. Fill the space in front of the removeable sleeve with the vacuum pump oil with which you operate the pump.

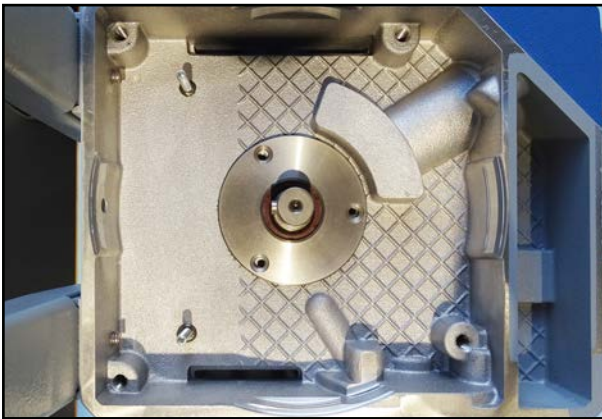

18. Insert the removeable sleeve.



19. Screw the removeable sleeve tight.

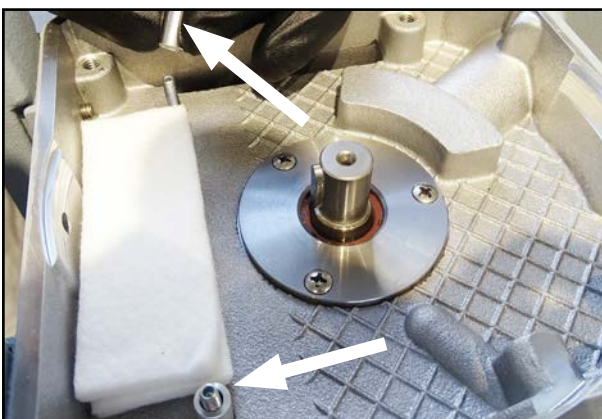

20. Place the (if necessary new) suction felts in the housing.
21. Insert the spacers.



22. Place the cover plate and screw the cover of the suction felt.



23. Insert the fan wheel with the coupling and push the fan wheel in as far as it will go.

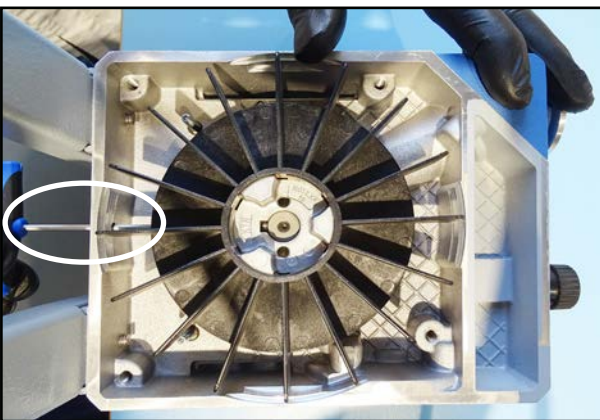

24. Screw the coupling tight (grub screw in the coupling).

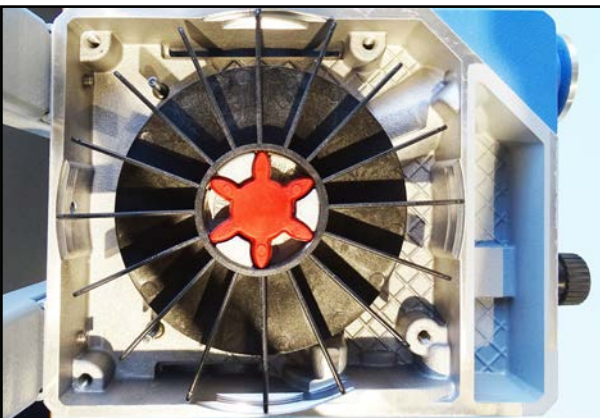

25. Position the cross coupling.

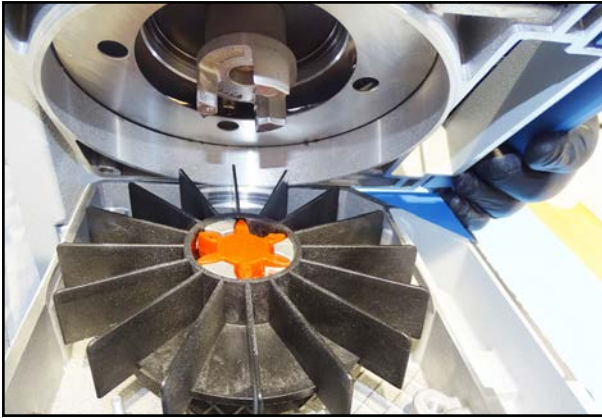

26. Carefully place the motor in the housing.
⇒ The terminal box of the motor must be aligned in the direction of the pump.



27. Screw the motor tight.
⇒ Recommended torque: 12 Nm.



28. Place the pump on the pump feet.
29. Let the pump run for approx. 1 hour with the outlet open, the gas ballast valve open and the inlet port closed.



DANGER

Danger of electric shock.

Danger of electric shock due to improperly executed repairs.

- ⇒ Check the electrical safety of the device according to IEC 61010 and national regulations after repair.
- ⇒ Check the protective conductor resistance.
- ⇒ Check the insulation resistance.
- ⇒ Carry out a high voltage test.
- ⇒ Check the leakage current according to DIN EN 50678:2021 (EN 50678:2020) and national regulations.

4.3 Maintenance RE 9



1. Unscrew the oil drain plug and drain the oil.
2. Screw the oil drain plug back in.

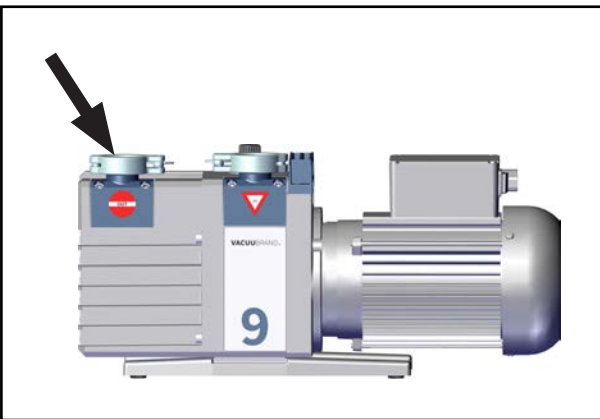

3. Close the pump outlet.



4. Place the pump on the oil reservoir (on the rating plate).



5. Unscrew the motor.



6. Lift off the motor.



7. Remove the cross coupling.

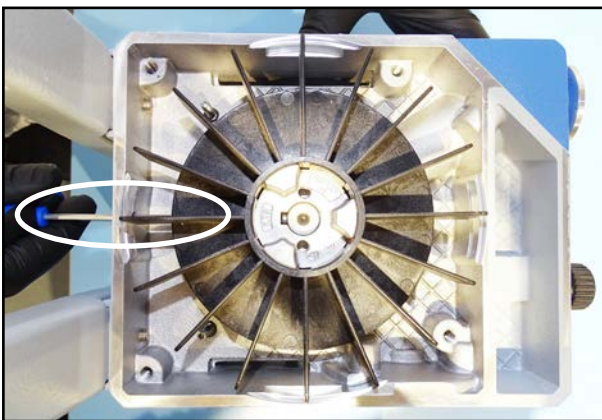

8. Loosen the coupling by turning the grub screw in the coupling (one turn).
⇒ Do not unscrew the grub screw completely.

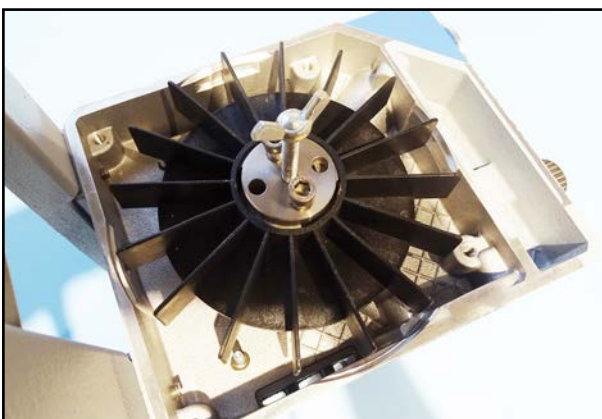

9. Place the pull-off disk on the coupling and insert the wing screw and the two cylinder screws.



10. Screw in the cylinder screws.



11. Screw in the wing screw until the fan wheel with coupling is released.

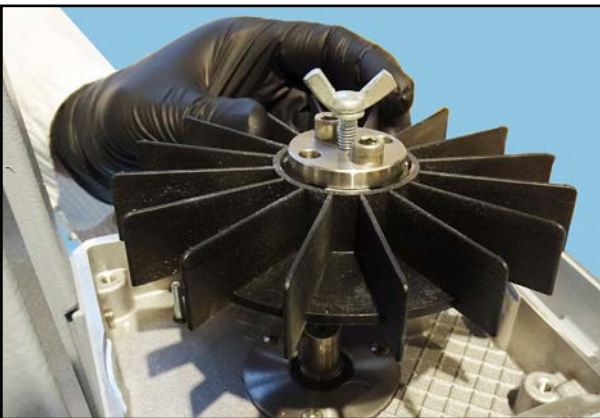

12. Remove the fan wheel with coupling.

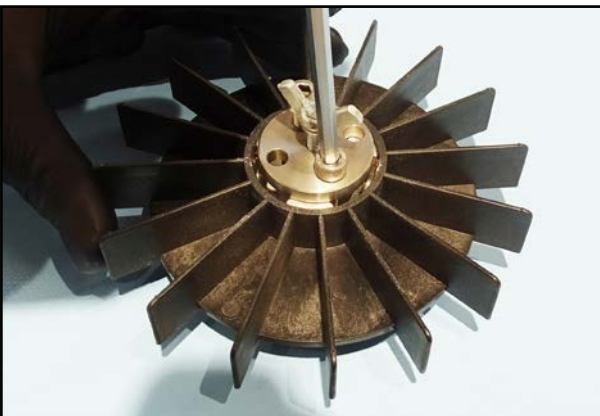

13. Remove the pull-off disk and the screws from the fan wheel.

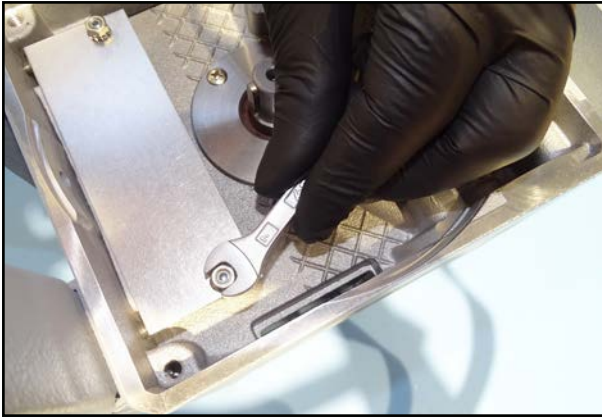

14. Unscrew the suction felt cover.

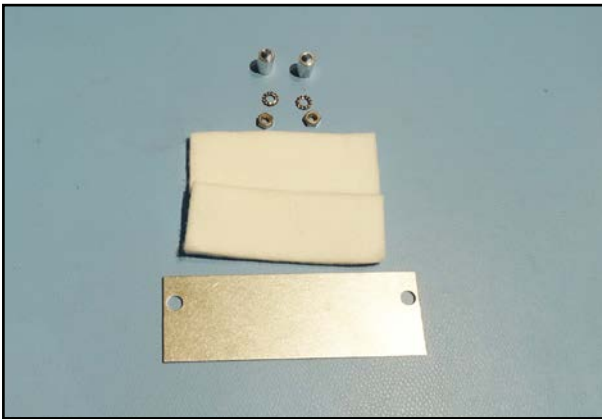

15. Replace the suction felts if they are soaked with oil.

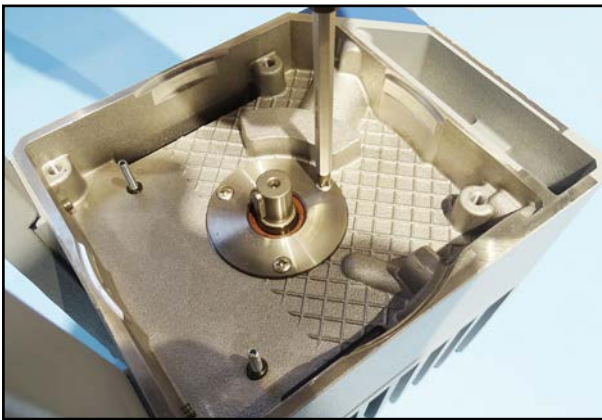

16. Unscrew the removable sleeve.

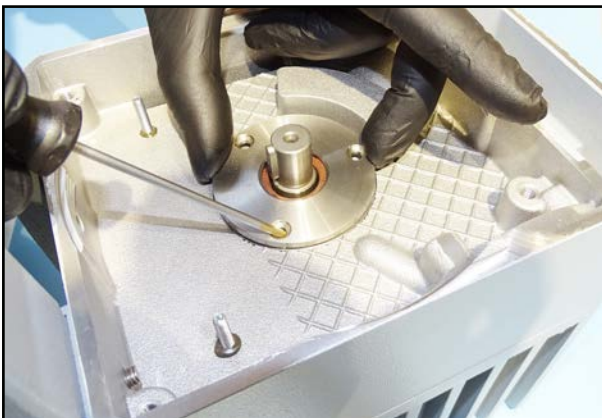

17. Lift off the removable sleeve.



18. Position the pump unit appropriately, e.g. on the edge of a table.



19. Loosen the screws on the oil reservoir.

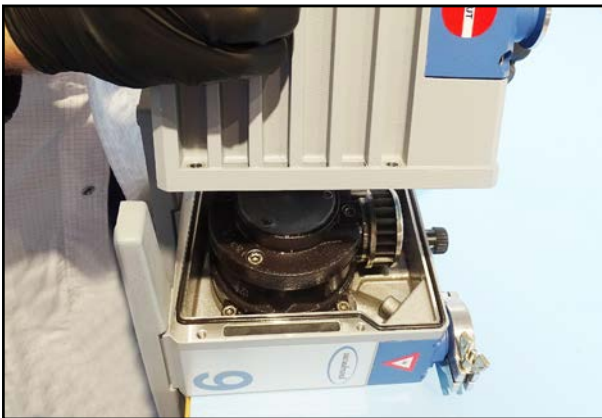

20. Lift off the oil reservoir.

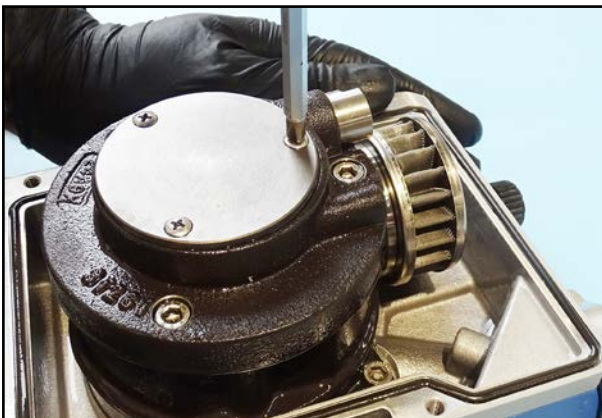

21. Unscrew the cover plate.



22. Lift off the cover plate.



23. Remove the seal on the bearing cover.

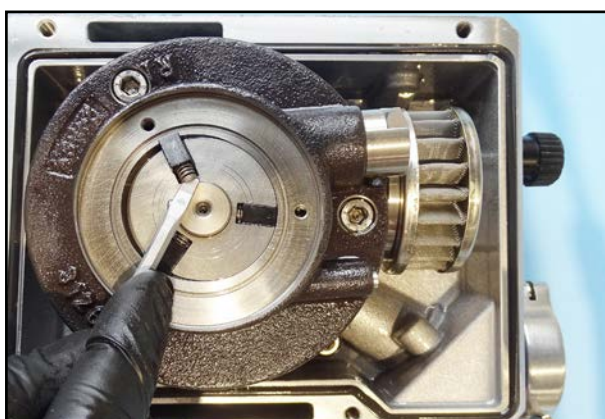

24. Pull the vanes and springs out of the rotor.

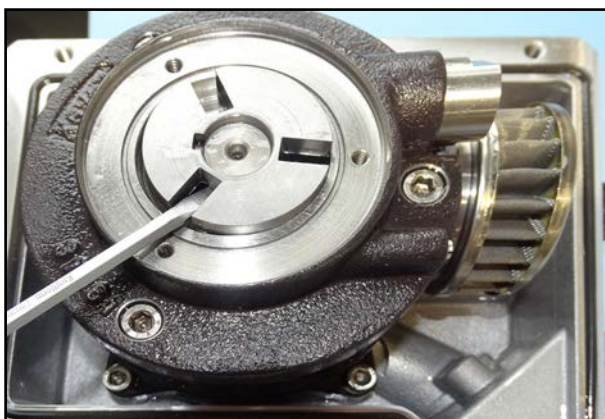

25. Remove the rotor.

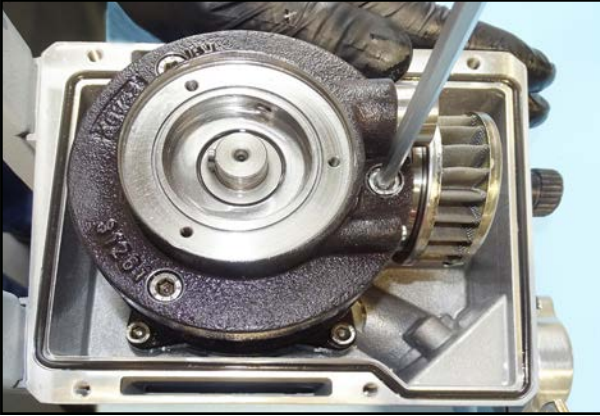

26. Unscrew the screws on the pump unit.



27. Pay attention to the Usit rings in the bearing cover.
⇒ The Usit rings must be reinstalled during assembly.

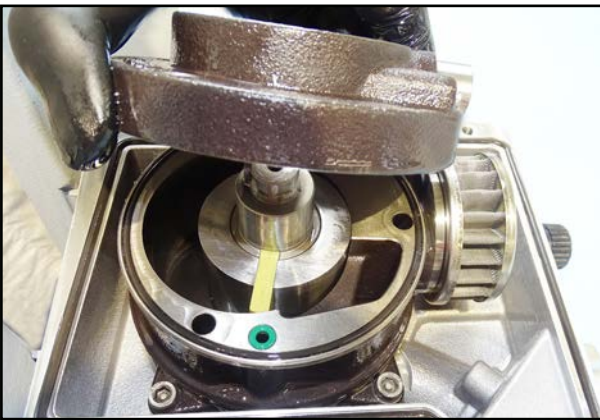

28. Lift off the bearing cover.

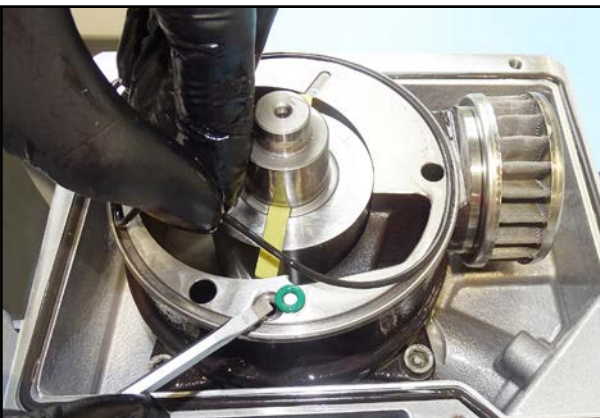

29. Remove the seals on the stator.



30. Lift off the stator.

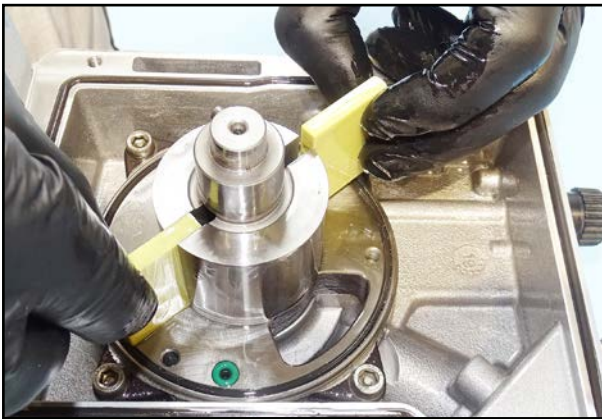

31. Pull the vanes and springs out of the rotor.



32. Lift off the rotor.

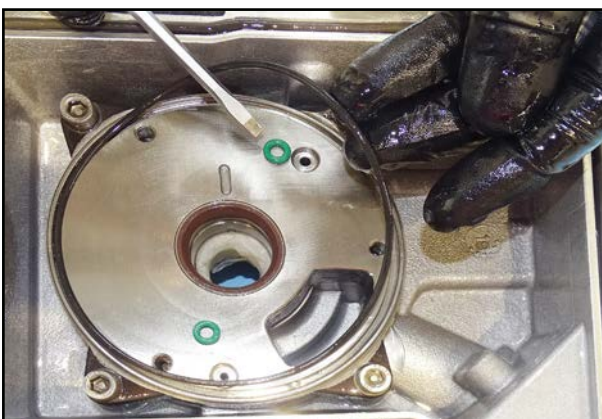

33. Remove the seals on the bearing plate.

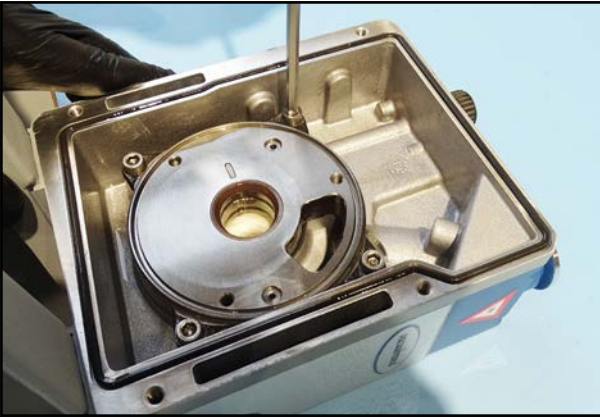

34. Unscrew the bearing plate.



35. Remove the bearing plate from the housing.

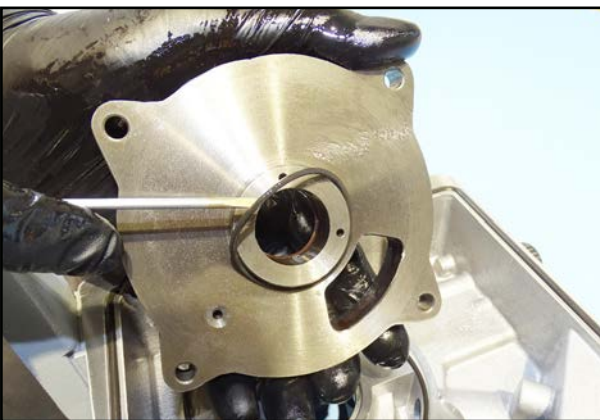

36. Remove the seal at the bearing plate.



37. Remove the seals in the housing.



38. Unscrew the screw plug of the oil retention valve from the bearing cover.

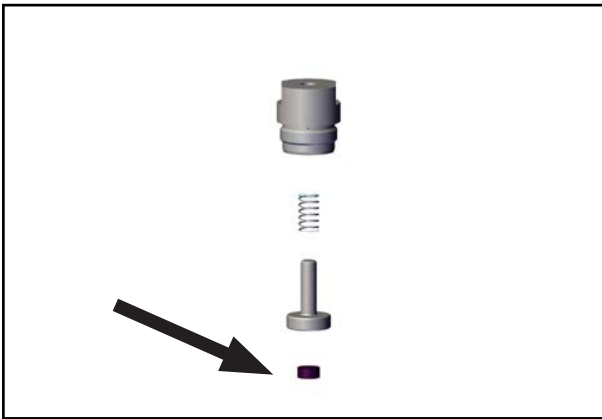

39. Disassemble the oil retention valve.
40. Replace the oil retention valve seal.



41. Unscrew the noise damping nozzle from the bearing cover.

⇒ Attention: The nozzle is glued in place with Omnifit® 50M locking adhesive.

42. Check the nozzle for patency.

43. Replace a dirty nozzle.

44. Use Omnifit® 50M locking adhesive and screw the nozzle back in.



45. Press the shaft seal out of the bearing cover using a flat blade screwdriver.

⇒ Do not damage the surfaces.



46. Press the shaft seal out of the bearing plate using a flat-blade screwdriver.
⇒ Do not damage the surfaces.

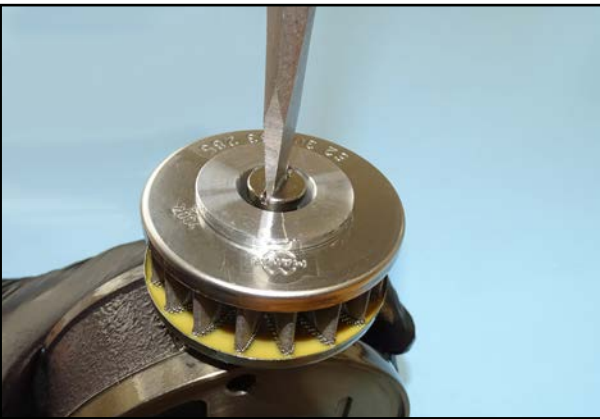

47. Unscrew the oil separator.



48. Remove the screw and the spring.



49. Unscrew the pressure disk.



50. Remove the pressure disk.
51. Remove the cap and the spring.



52. Clamp the press-fit mandrel 3 in a drill press.
53. Observe the correct alignment of the shaft seal, see also section „Press-fit mandrel“.



54. Place the shaft seal on the press-fit mandrel.



55. Press the shaft seal into the bearing cover as far as it will go.



56. Clamp the press-fit mandrel 3 in a drill press.
57. Observe the correct alignment of the shaft seal, see also section „Press-fit mandrel“.



58. Place the shaft seal on the press-fit mandrel.



59. Press the shaft seal into the bearing plate as far as it will go.



60. Insert a new cap and spring into the stator.

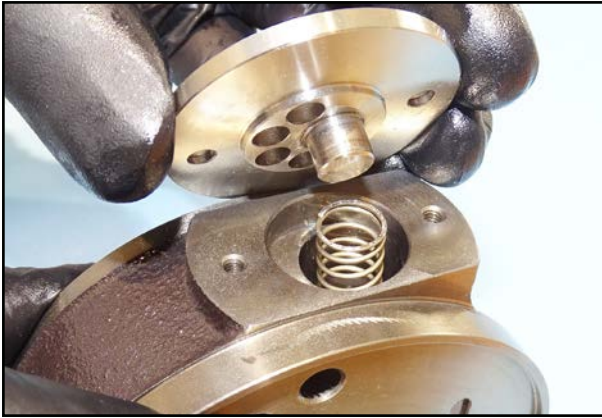

61. Insert the pressure plate.

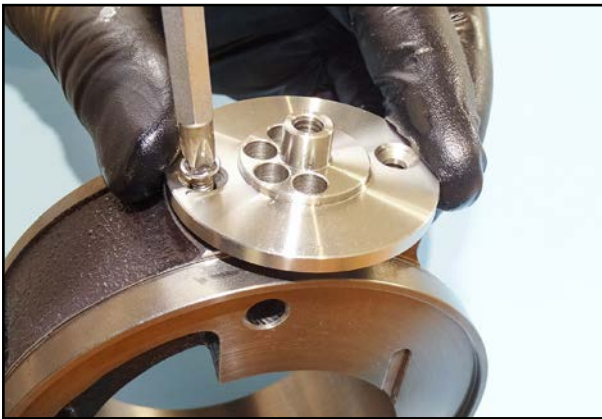

62. Screw the pressure plate tight.

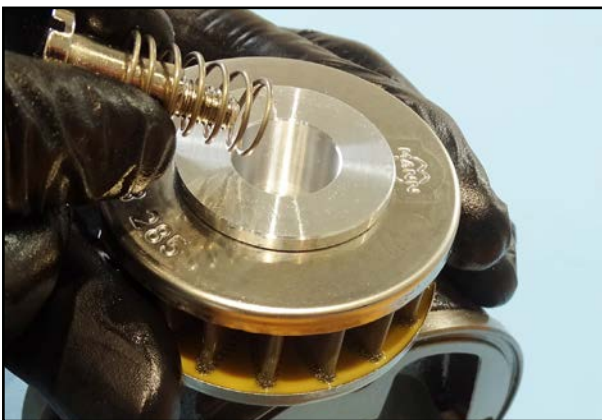

63. Insert the oil separator and tighten the oil separator with the spring and the screw.



64. Assemble the oil retention valve with housing.



65. Screw the retaining device into the bearing cover.

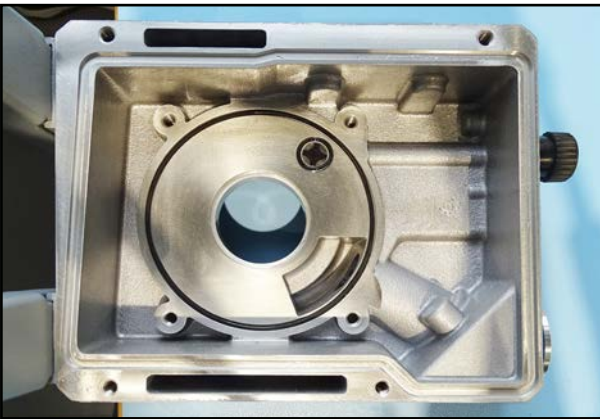

66. Place the seals in the housing.



67. Place the O-ring around the bearing plate.

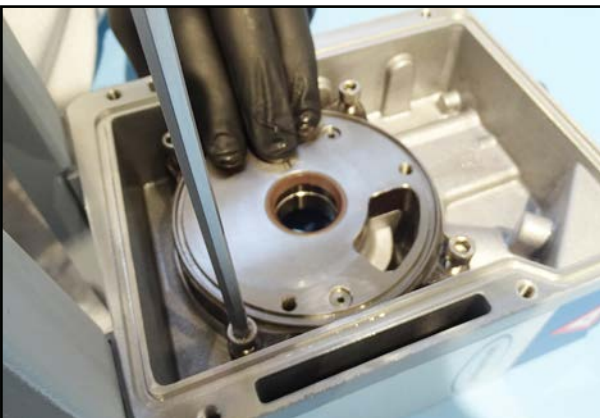

68. Place the bearing plate in the housing and screw the bearing plate tight.

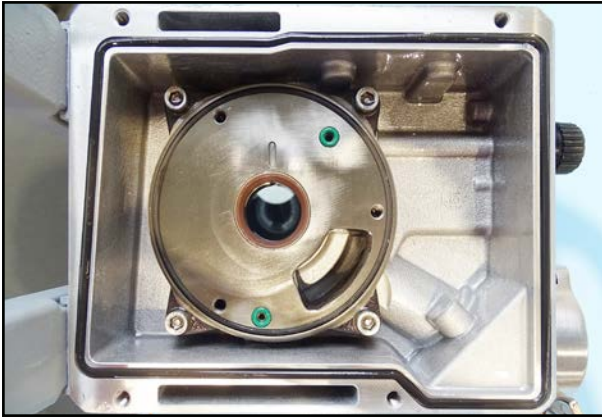

69. Place the seals in the bearing plate.
70. Place the oil reservoir seal.

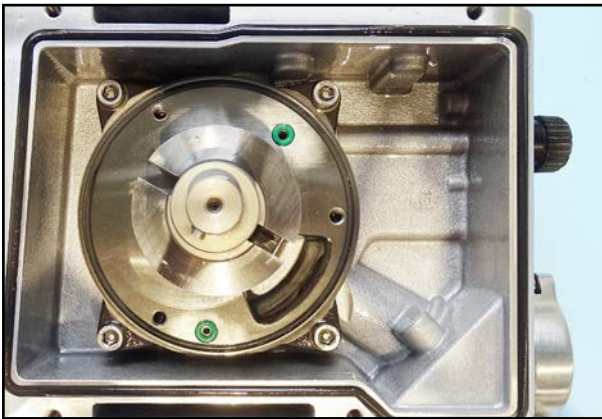

71. Insert the rotor.



72. Insert the vanes with springs into the rotor.

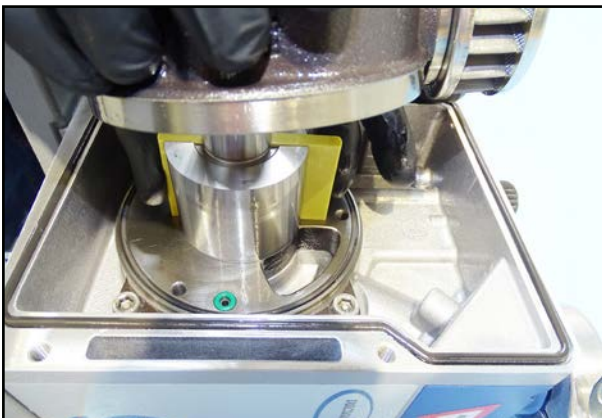

73. Press the vanes together and insert the stator.

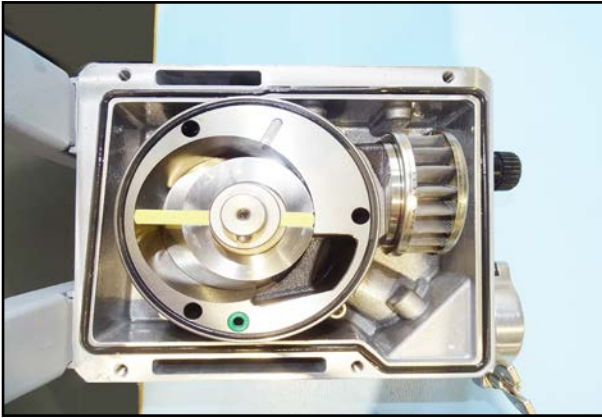

74. Place the seals in the stator.

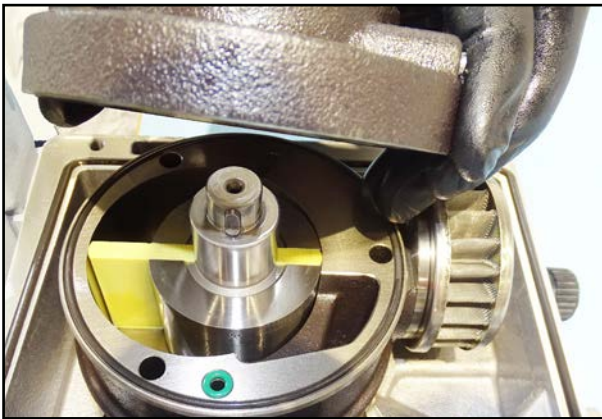

75. Insert the bearing cover.

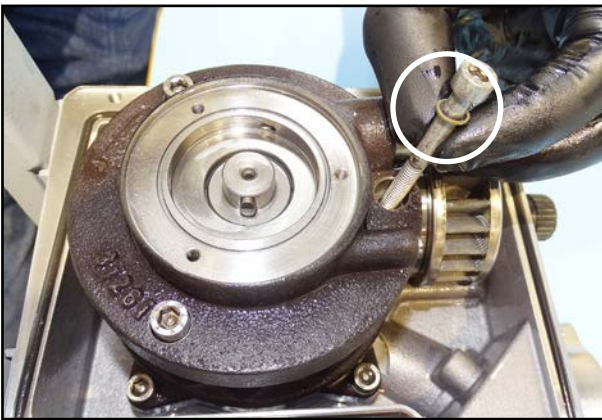

76. Insert the screws with Usit rings into the holes in the bearing cover.

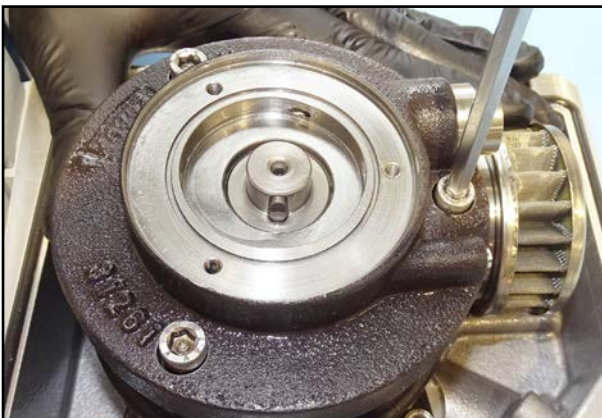

77. Screw the pump unit together.
⇒ Recommended torque: 9 Nm.

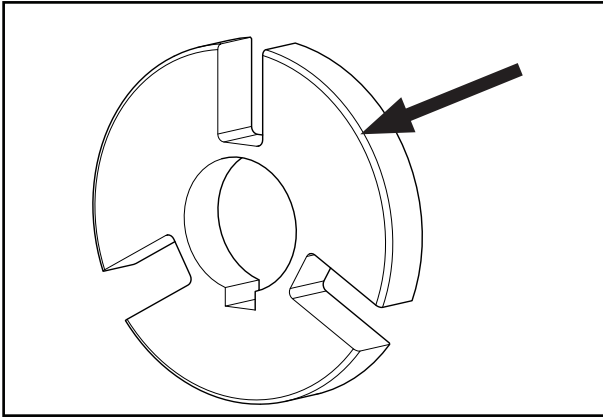

⇒ Attention: The oil pump rotor has a chamfer on one side.

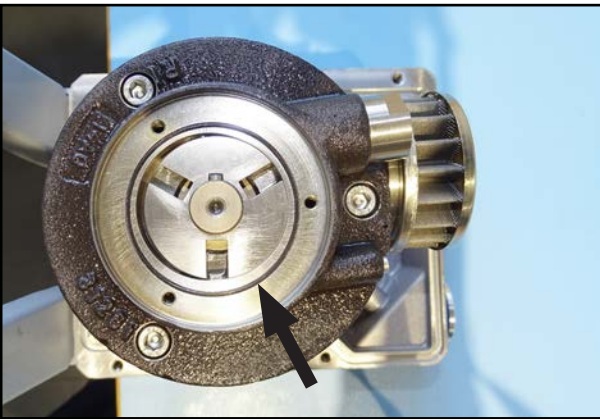

78. Be sure to place the oil pump rotor in the bearing cover so that the chamfer is on the side of the bearing cover.

79. Place the seal in the bearing cover.

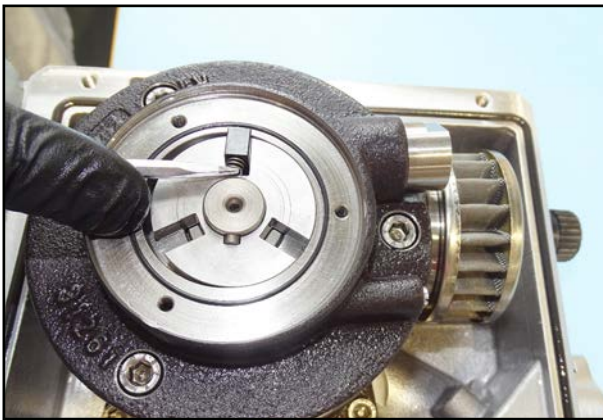

80. Insert the vanes with springs.



81. Fill the space around the rotor with the vacuum pump oil with which you operate the pump.

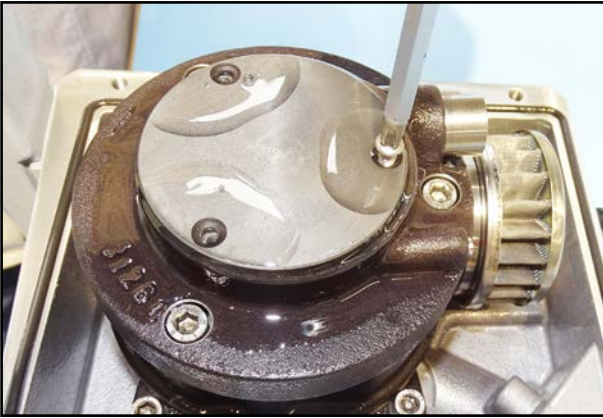

82. Screw the cover plate tight.



83. Place the oil reservoir on the housing.

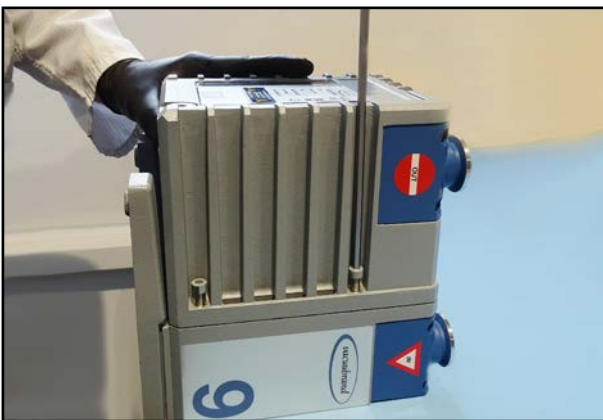

84. Screw the oil reservoir tight.



85. Turn the pump and fill the space in front of the removeable sleeve with the vacuum pump oil with which you operate the pump.



86. Place the O-ring around the new removeable sleeve.

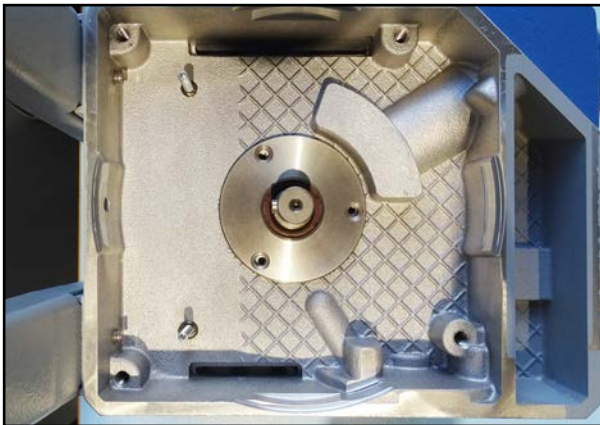

87. Insert the removeable sleeve.



88. Screw the removeable sleeve tight.

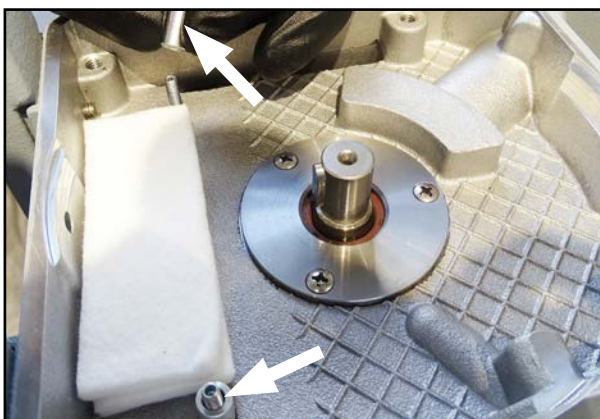

89. Place the (if necessary new) suction felts in the housing.

90. Insert the spacer.

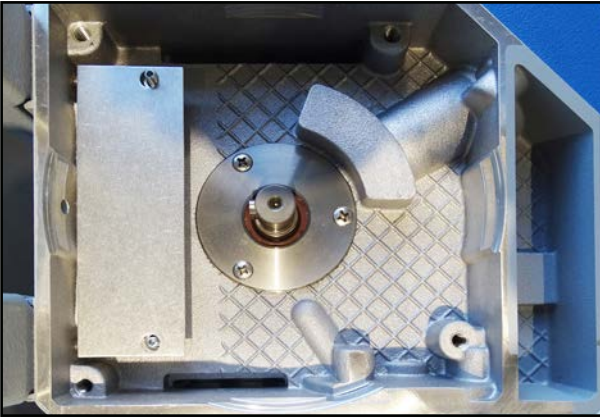

91. Insert the suction felt cover.

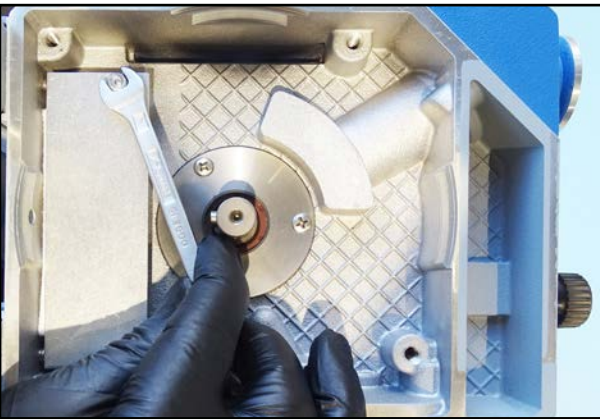

92. Screw the suction felt cover tight.

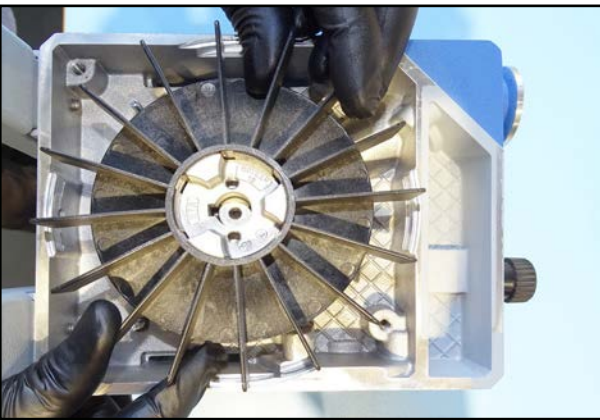

93. Insert the fan wheel with the coupling and push the fan wheel in as far as it will go.

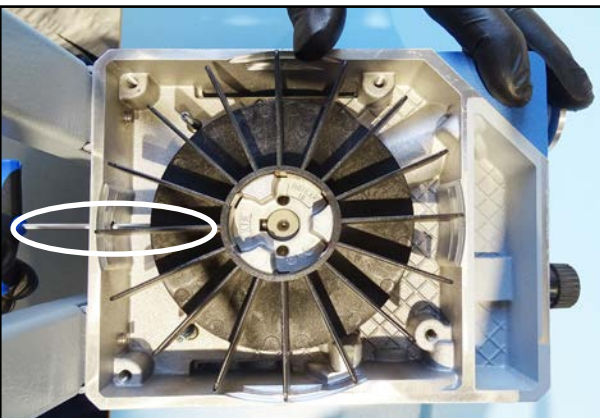

94. Tighten the fan wheel (grub screw in the coupling).

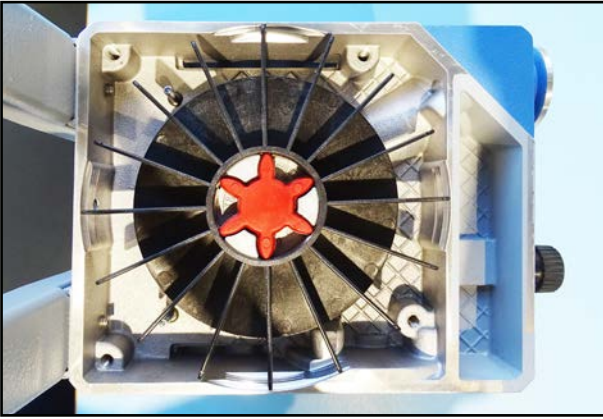

95. Insert the cross coupling.

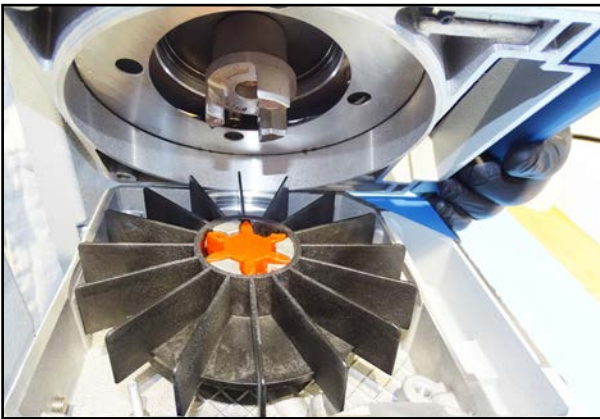

96. Carefully place the motor in the housing.



97. Screw the motor tight.

⇒ The terminal box of the motor must be aligned in the direction of the pump handle.

⇒ Recommended torque: 12 Nm.



98. Place the pump on the pump feet.



99. Unscrew the small flange connections at the inlet and the outlet.

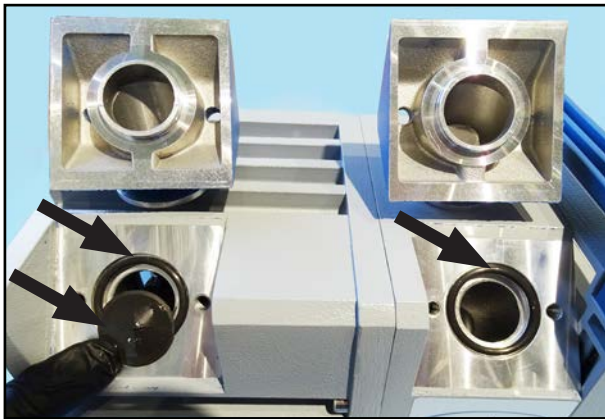

100. Replace the seals at the inlet and the outlet.

101. Replace the blind at the outlet.

102. Screw the inlet and the outlet tight.



103. Remove the gas ballast cap.



104. Remove the insulating material from the gas ballast connection.

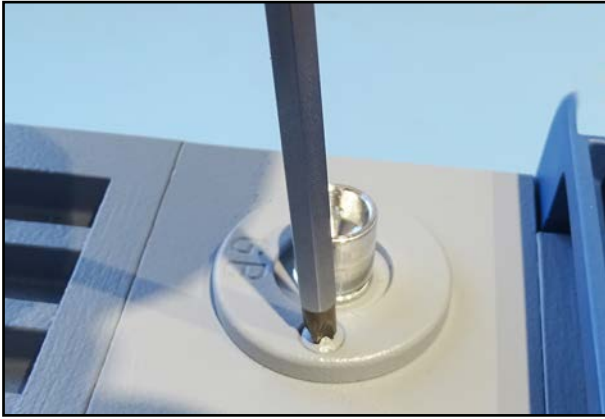

105. Unscrew the blind.



106. Remove the gas ballast connection.

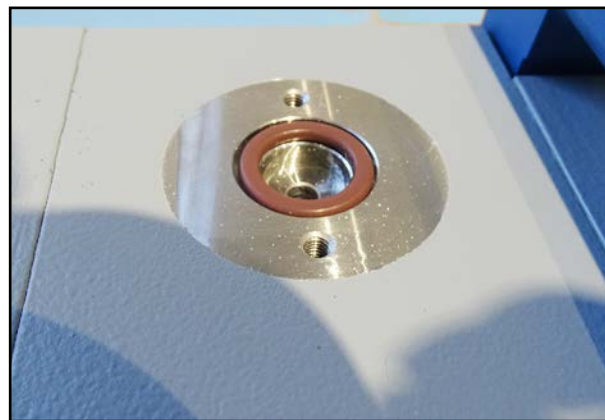

107. Replace the seal at the gas ballast connection.



108. Insert the gas ballast connection.

109. Obey the orientation of the gas ballast connection.

⇒ The hole must face outwards (facing away from the pump inlet).

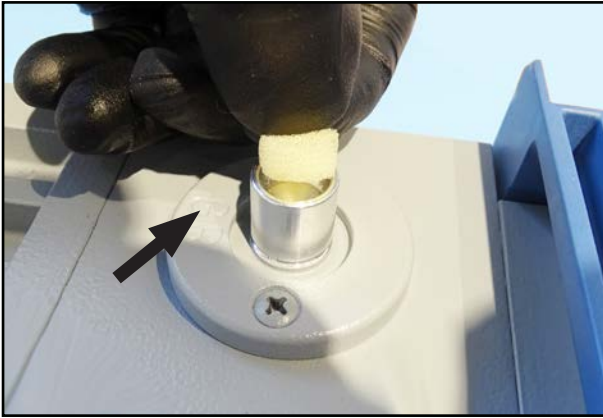

110. Screw the blind of the gas ballast connection tight.

⇒ The mark „GB“ on the blind must point in direction of the oil reservoir.

111. Insert new insulating material in the gas ballast connection.



112. Insert the gas ballast cap.



113. Unscrew the oil inlet screw.

114. Fill in oil.

⇒ The oil level must be between the „Min.“ and „Max.“ markings on the rating plate.



115. Screw in the oil inlet screw.



116. Let the pump run for approx. 1 hour with the outlet open, the gas ballast valve open and the inlet closed.



DANGER

Danger of electric shock.

Improperly executed repairs will result in an electrical shock.

- ⇒ Check the electrical safety of the device according to IEC 61010 and national regulations after repair.
- ⇒ Check the protective conductor resistance.
- ⇒ Check the insulation resistance.
- ⇒ Carry out a high voltage test.
- ⇒ Check the leakage current according to DIN EN 50678:2021 (EN 50678:2020) and national regulations.

4.4 Maintenance RZ 9



1. Unscrew the oil drain plug and drain the oil.
2. Screw the oil drain plug back in.

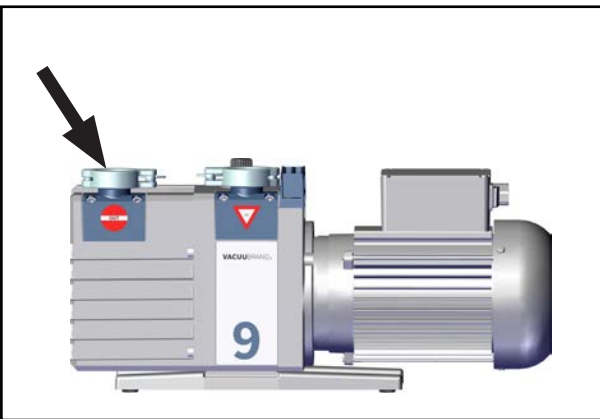

3. Close the pump outlet.



4. Place the pump on the oil reservoir (on the rating plate).



5. Unscrew the motor.



6. Lift off the motor.

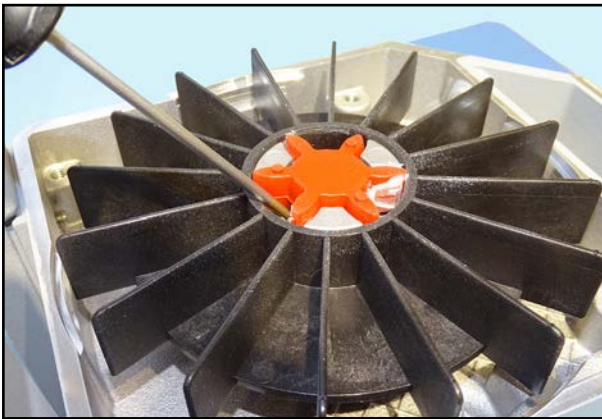

7. Remove the cross coupling.

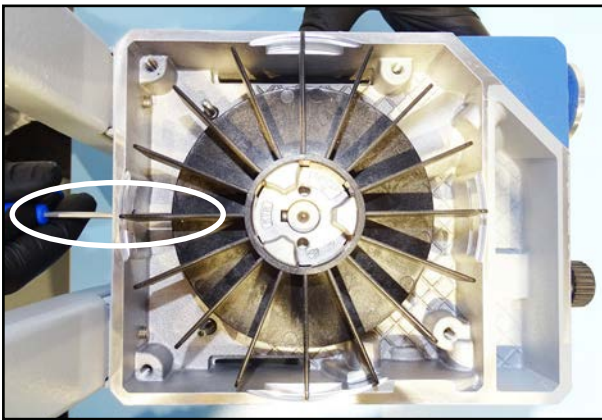

8. Loosen the coupling by turning the grub screw in the coupling (one turn).
⇒ Do not unscrew the grub screw completely.

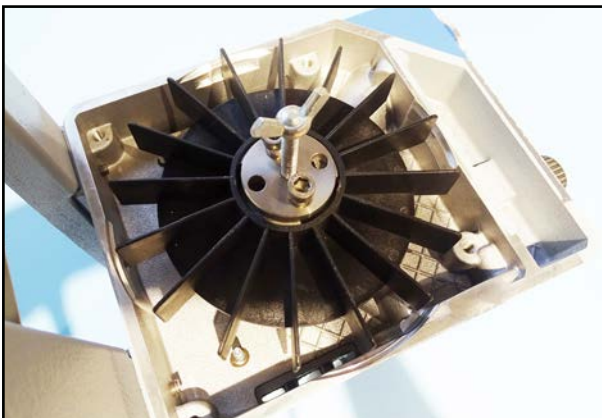

9. Place the pull-off disk on the coupling and insert the wing screw and the two cylinder screws.



10. Screw in the cylinder screws.



11. Screw in the wing screw until the fan wheel with coupling is released.

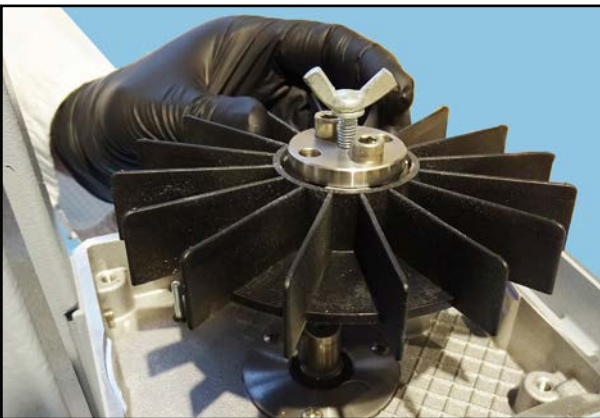

12. Remove the fan wheel with coupling.

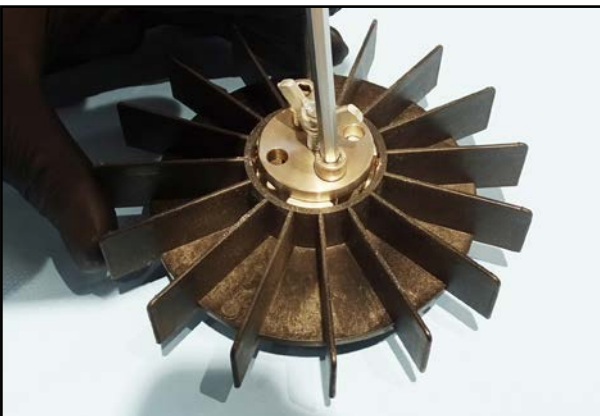

13. Remove the pull-off disk and the screws from the fan wheel.

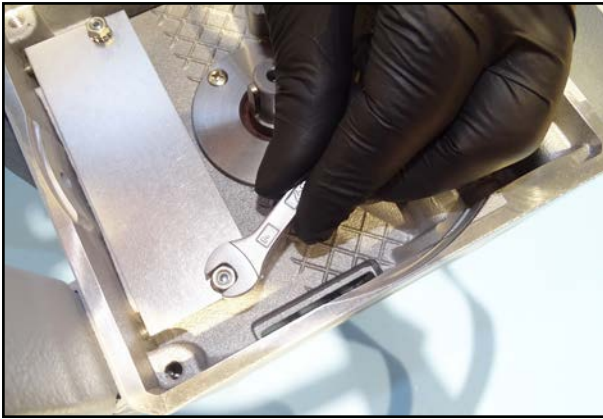

14. Unscrew the suction felt cover.

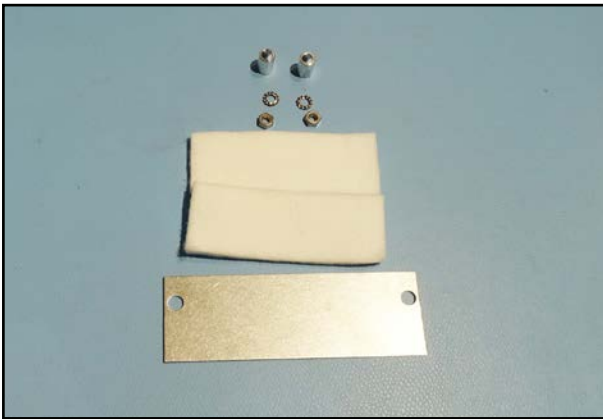

15. Replace the suction felts if they are soaked with oil.

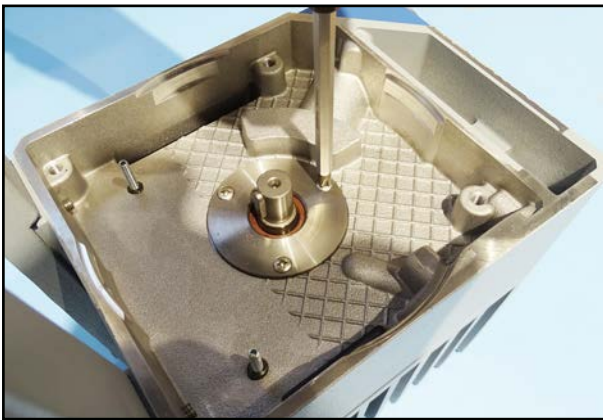

16. Unscrew the removeable sleeve.

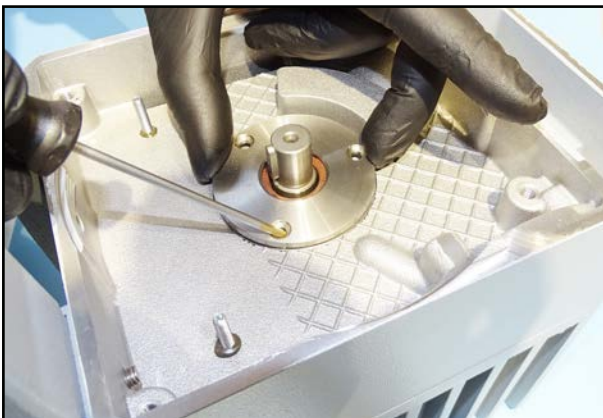

17. Lift off the removeable sleeve.



18. Position the pump unit appropriately, e.g. on the edge of a table.



19. Loosen the screws on the oil reservoir.

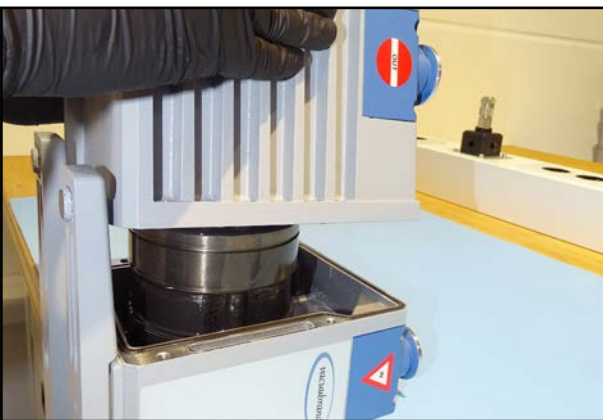

20. Lift off the oil reservoir.

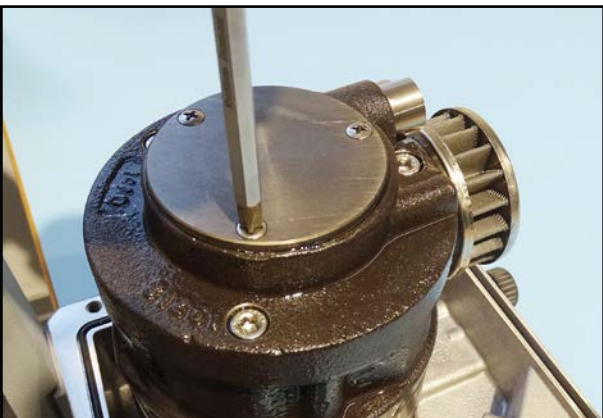

21. Unscrew the cover plate.



22. Lift off the cover plate.

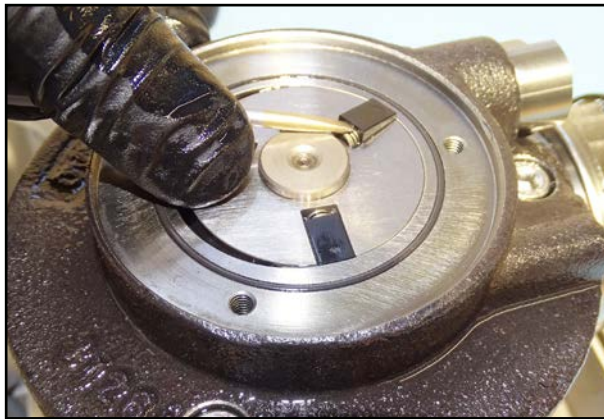

23. Pull the vanes and springs out of the rotor.

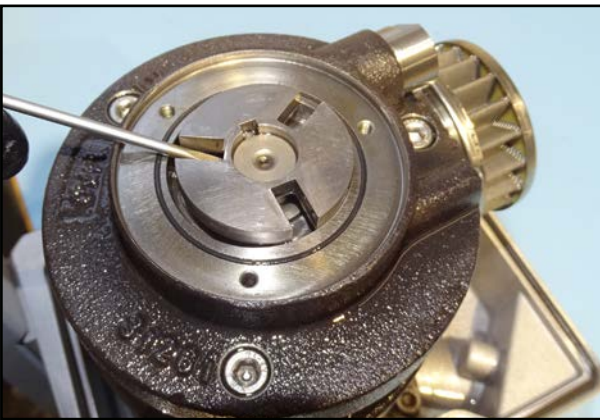

24. Remove the rotor.

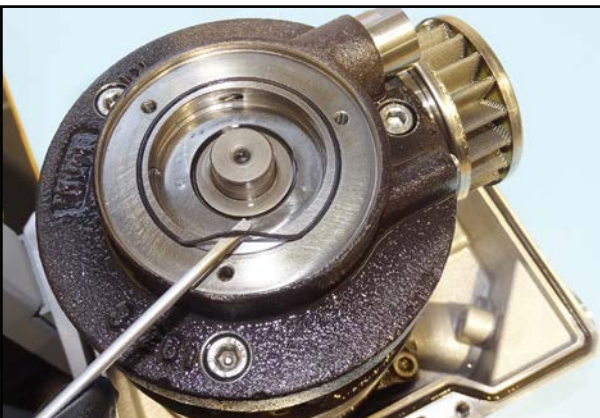

25. Remove the seal on the bearing cover.

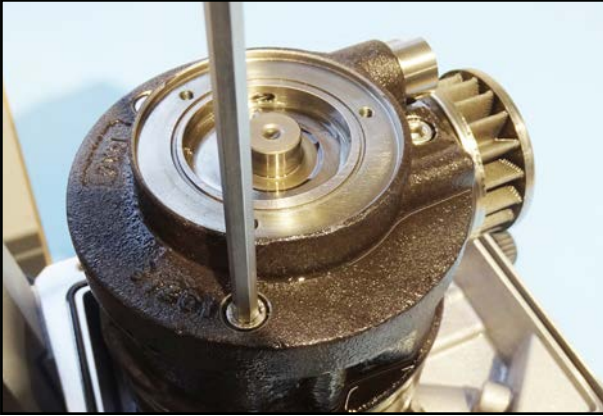

26. Unscrew the screws on the pump unit.

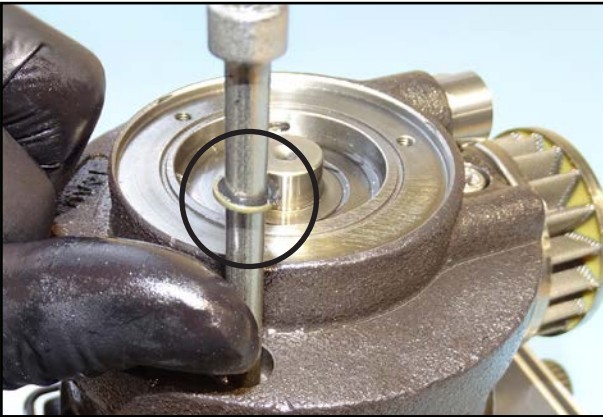

27. Pay attention to the Usit rings in the bearing cover.
⇒ The Usit rings must be reinstalled during assembly.



28. Lift off the bearing cover.

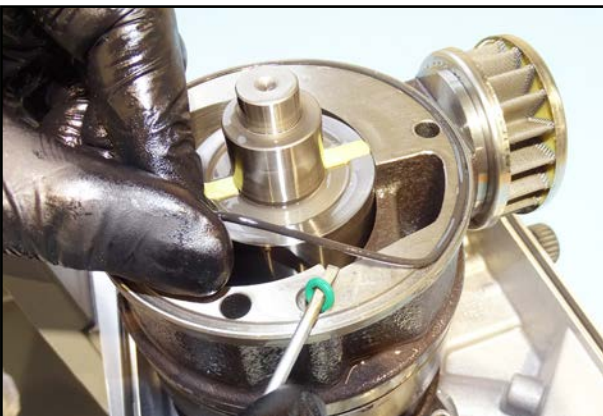

29. Remove the seals on the stator.



30. Lift off the stator.



31. Pull the vanes and springs out of the rotor.



32. Lift off the rotor.

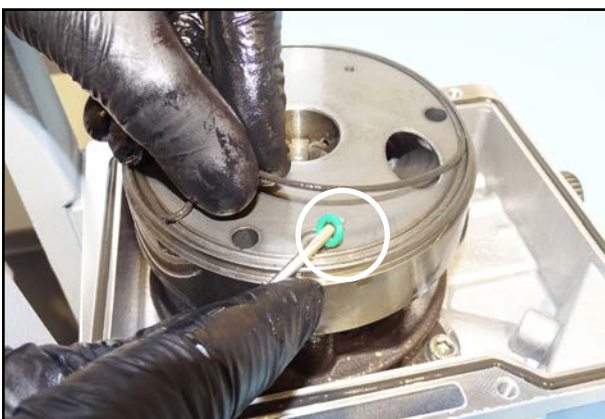

33. Remove the seals on the intermediate bearing.



34. Remove the intermediate bearing.

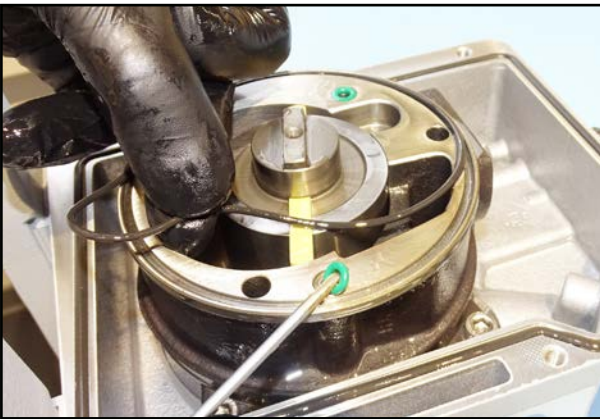

35. Remove the seals on the stator.



36. Lift off the stator.

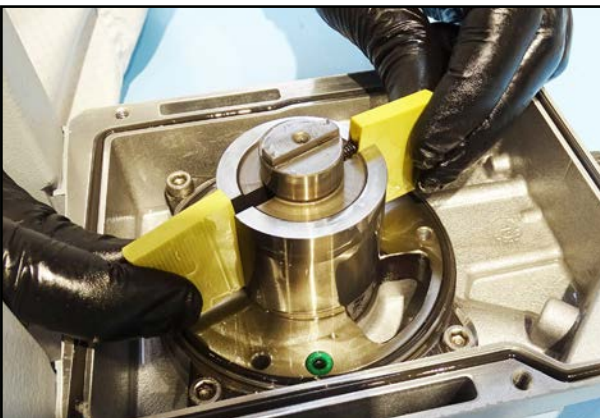

37. Pull the vanes and springs out of the rotor.



38. Lift off the rotor.



39. Remove the seals on the bearing plate.

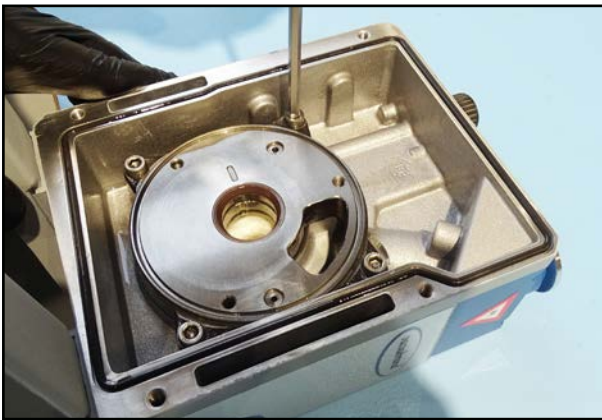

40. Unscrew the bearing plate.



41. Remove the bearing plate from the housing.

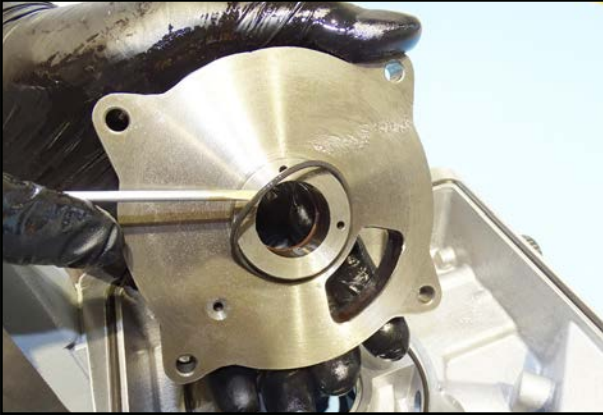

42. Remove the seal at the bearing plate.

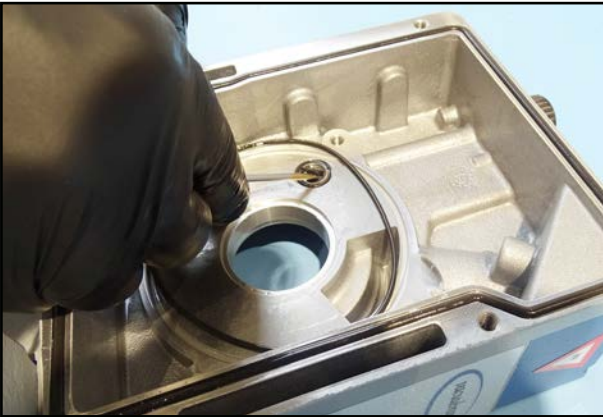

43. Remove the seals in the housing.



44. Remove the oil reservoir seal.



45. Unscrew the screw plug of the oil retention valve from the bearing cover.

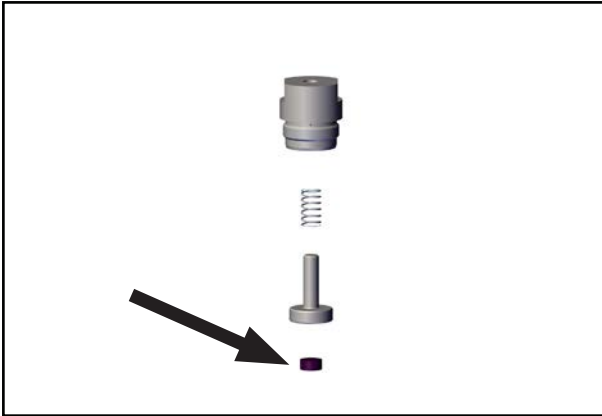

46. Disassemble the oil retention valve.
47. Replace the oil retention valve seal.



48. Unscrew the noise damping nozzle from the bearing cover.
 - ⇒ Attention: The nozzle is glued in place with Omnifit® 50M locking adhesive.
49. Check the nozzle for patency.
50. Replace a dirty nozzle.
51. Use Omnifit® 50M locking adhesive and screw the nozzle back in.



52. Press the shaft seal out of the bearing cover using a flat blade screwdriver.
 - ⇒ Do not damage the surfaces.



53. Press the shaft seal out of the bearing plate using a flat-blade screwdriver.
 - ⇒ Do not damage the surfaces.



54. Unscrew the oil separator.



55. Remove the screw and the spring.

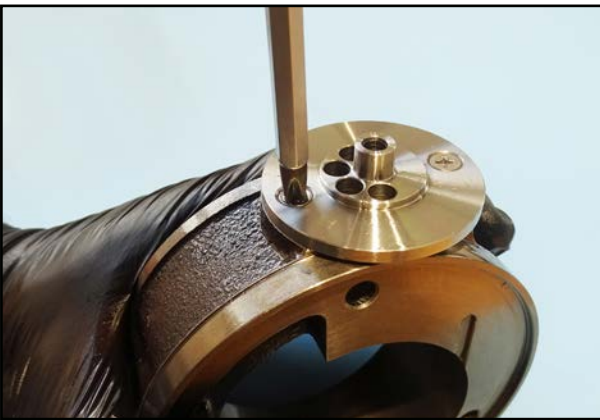

56. Unscrew the pressure disk.

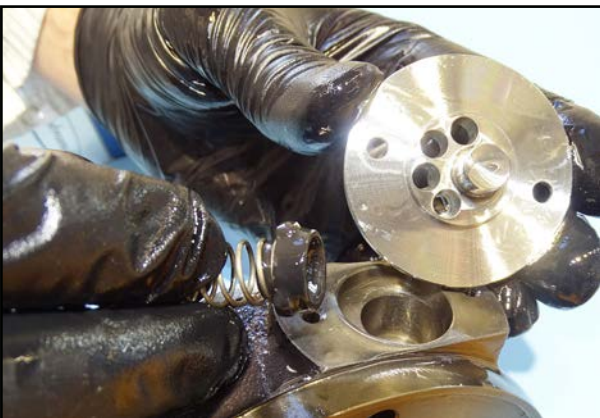

57. Remove the pressure disk.

58. Remove the cap and the spring.



59. Clamp the press-fit mandrel 3 in a drill press.
60. Observe the correct alignment of the shaft seal, see also section „Press-fit mandrel“.



61. Place the shaft seal on the press-fit mandrel.



62. Press the shaft seal into the bearing cover as far as it will go.



63. Clamp the press-fit mandrel 3 in a drill press.
64. Observe the correct alignment of the shaft seal, see also section „Press-fit mandrel“.



65. Place the shaft seal on the press-fit mandrel.



66. Press the shaft seal into the bearing plate as far as it will go.



67. Insert a new cap and spring into the stator.

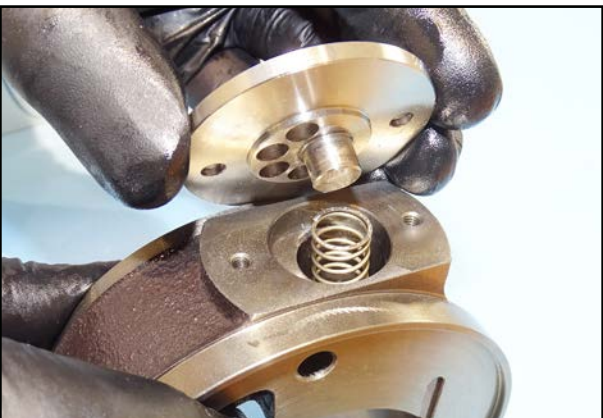

68. Insert the pressure plate.

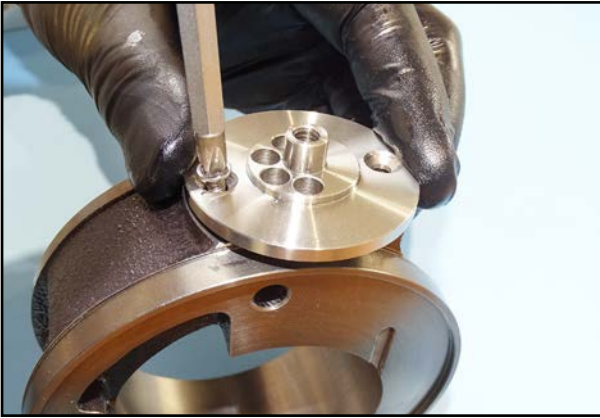

69. Screw the pressure plate tight.



70. Insert the oil separator and tighten the oil separator with the spring and the screw.



71. Assemble the oil retention valve with housing.



72. Screw the retaining device into the bearing cover.



73. Place the seals in the housing.



74. Place the O-ring around the bearing plate.

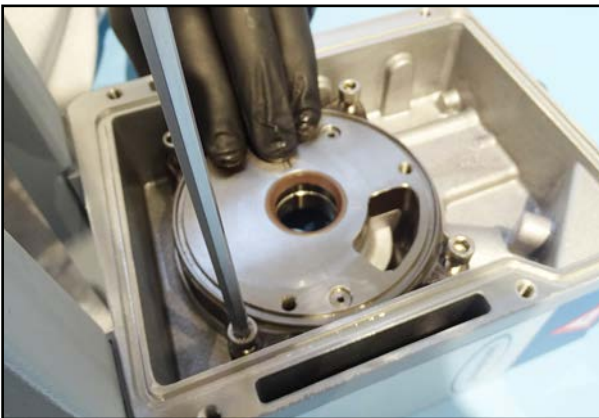

75. Place the bearing plate in the housing and screw the bearing plate tight.

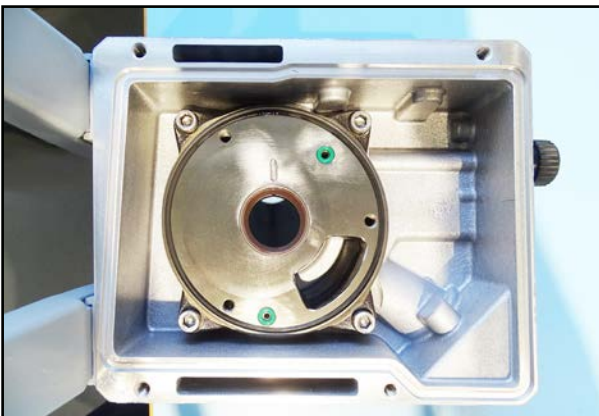

76. Place the seals in the bearing plate.

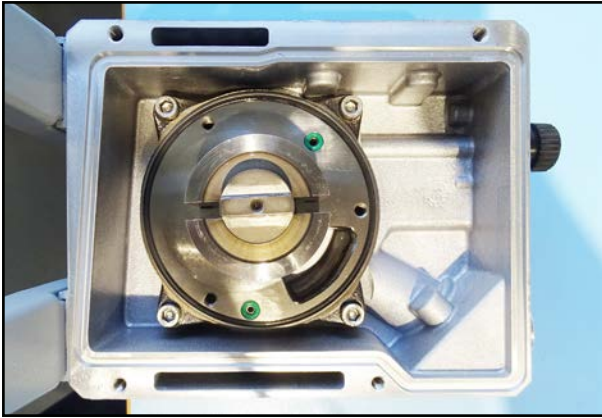

77. Insert the rotor.

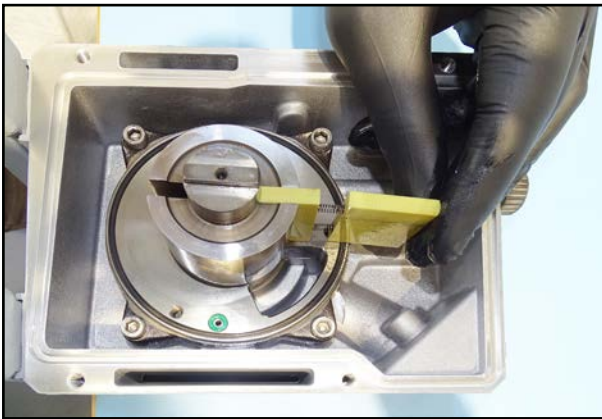

78. Insert the vanes with springs into the rotor.

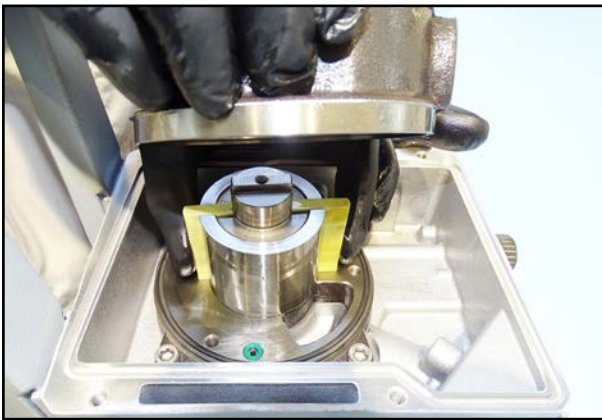

79. Press the vanes together and insert the stator.

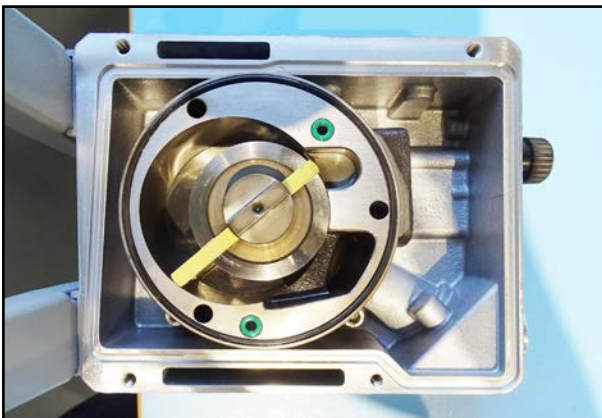

80. Place the seals in the stator.

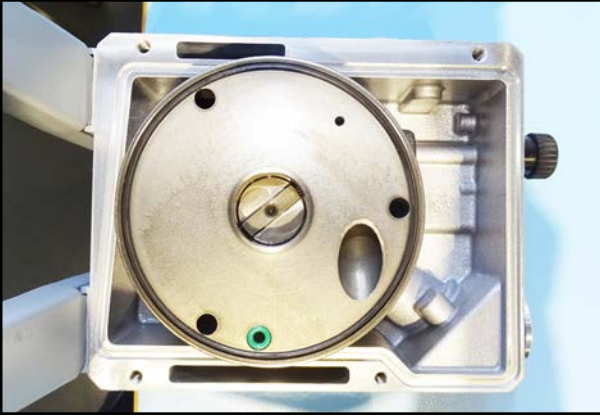

81. Insert the intermediate plate.
82. Place the seals in the intermediate plate.

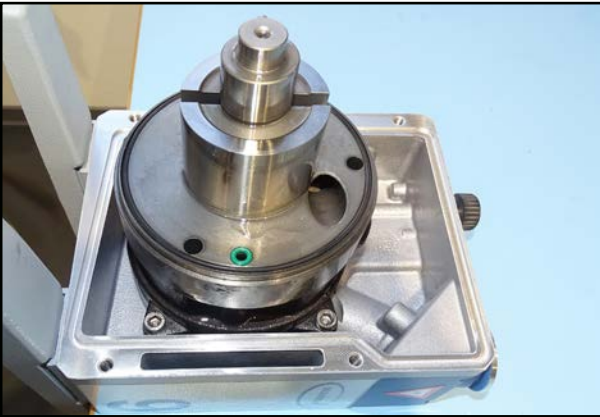

83. Insert the rotor.

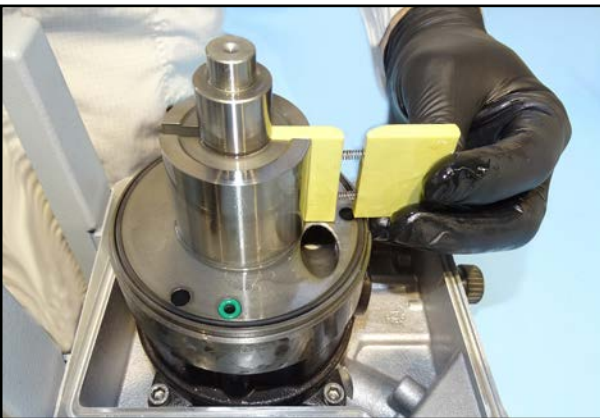

84. Insert the vanes with springs into the rotor.

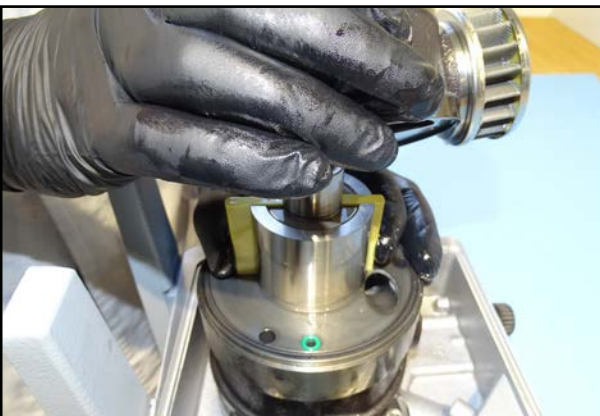

85. Press the vanes together and insert the stator.

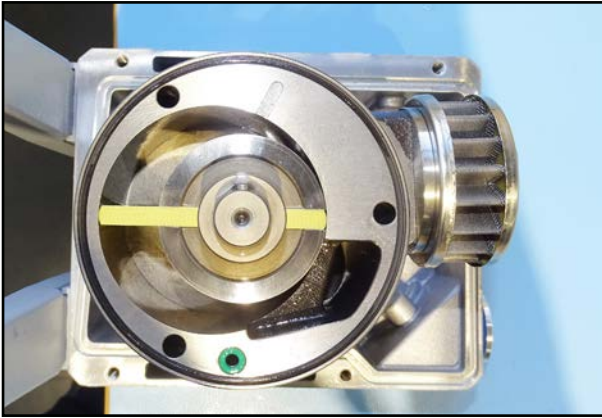

86. Place the seals in the stator.

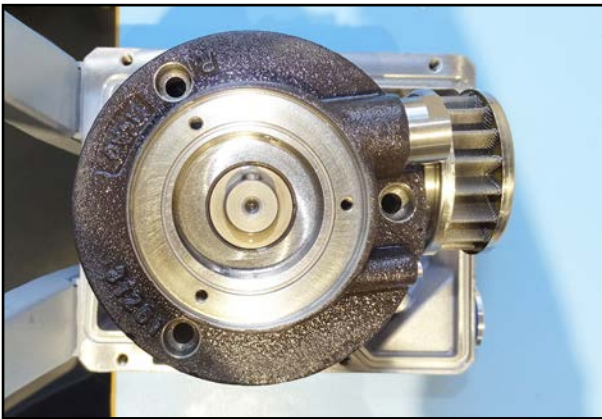

87. Insert the bearing cover.



88. Insert the screws with Usit rings into the holes in the bearing cover.

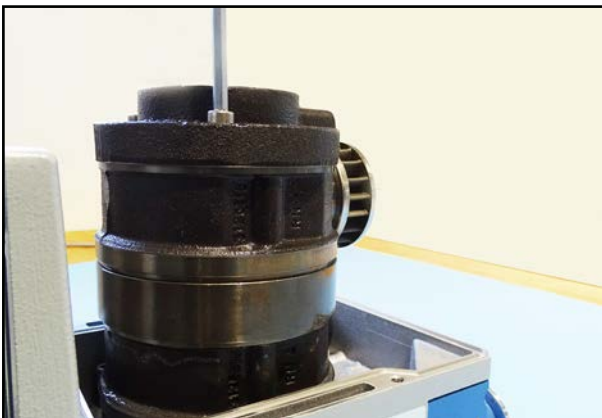

89. Screw the pump unit together.
⇒ Recommended torque: 9 Nm.

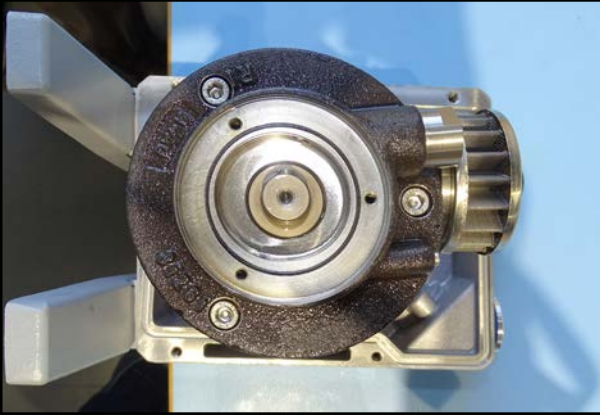

90. Place the seal in the bearing cover.

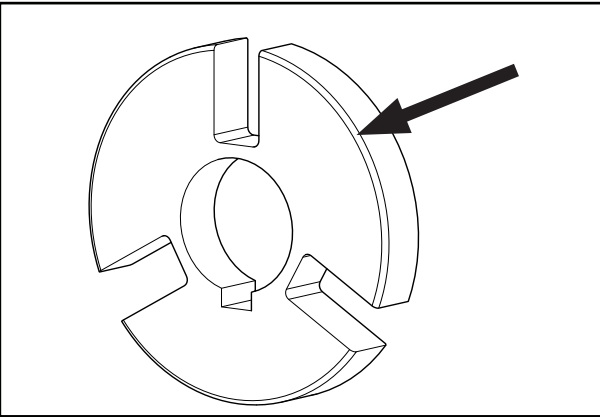

⇒ Attention: The oil pump rotor has a chamfer on one side.

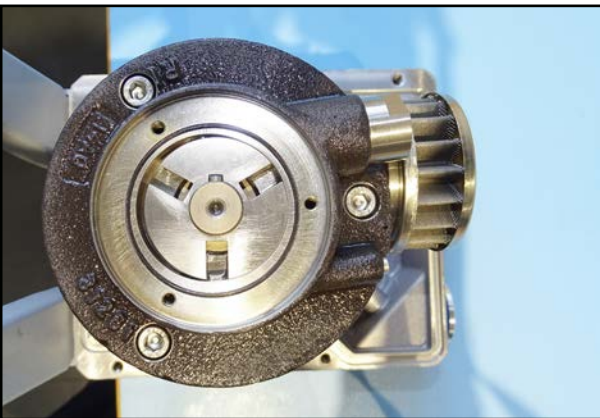

91. Be sure to place the oil pump rotor in the bearing cover so that the chamfer is on the side of the bearing cover.

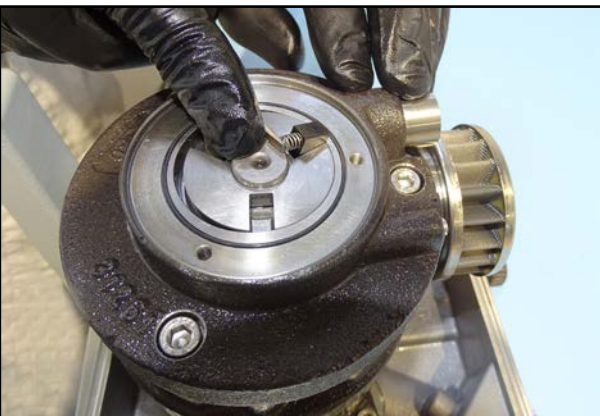

92. Insert the vanes with springs.

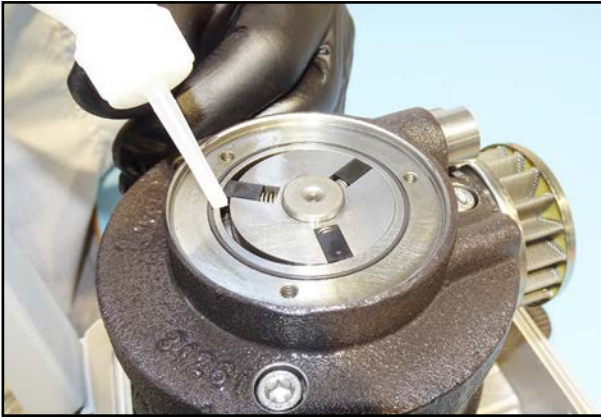

93. Fill the space around the rotor with the vacuum pump oil with which you operate the pump.

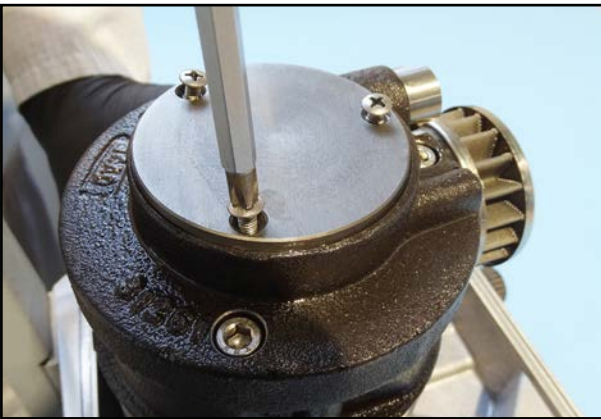

94. Screw the cover plate tight.

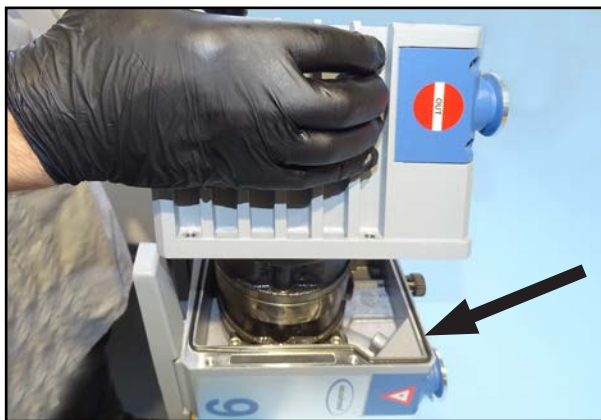

95. Place the seal in the housing.

96. Place the oil reservoir on the housing.

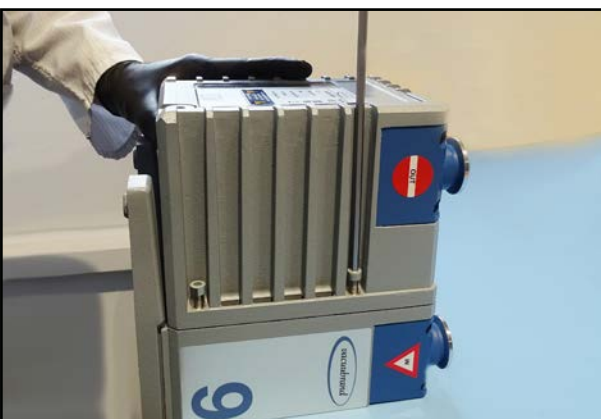

97. Screw the oil reservoir tight.



98. Turn the pump and fill the space in front of the removeable sleeve with the vacuum pump oil with which you operate the pump.



99. Place the O-ring around the new removeable sleeve.

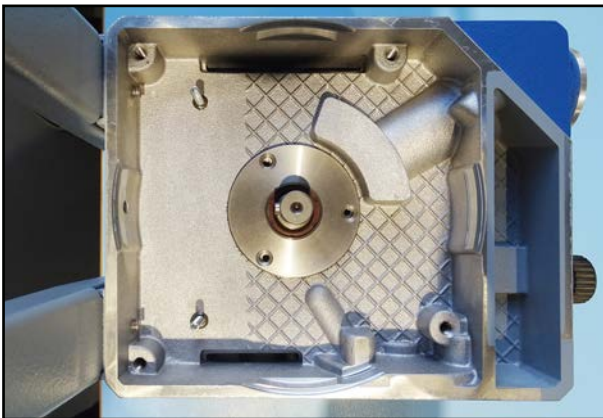

100. Insert the removeable sleeve.

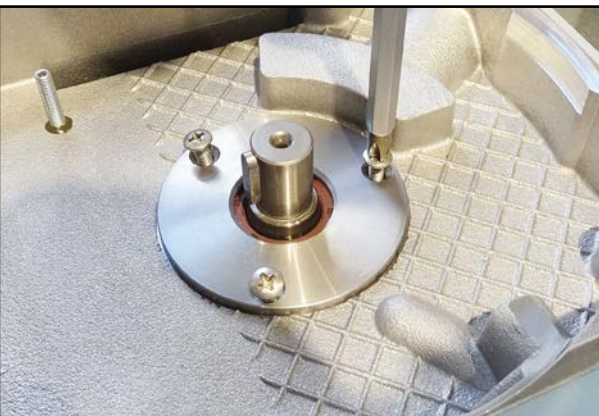

101. Screw the removeable sleeve tight.

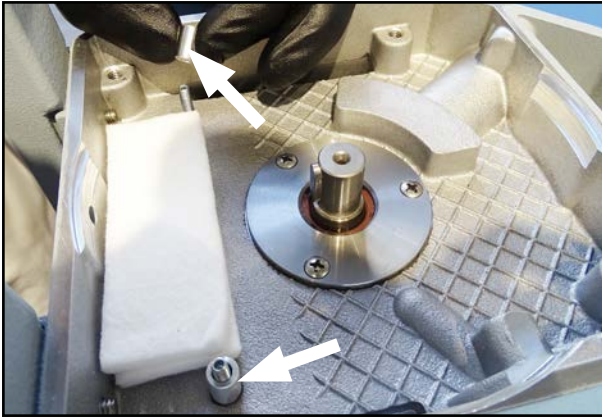

102. Place the (if necessary new) suction felts in the housing.
103. Insert the spacer.

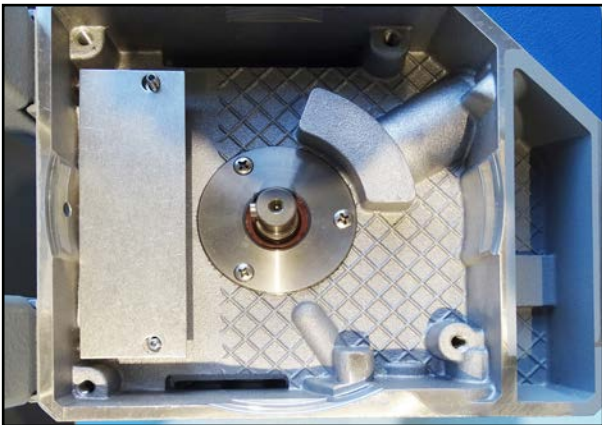

104. Insert the suction felt cover.

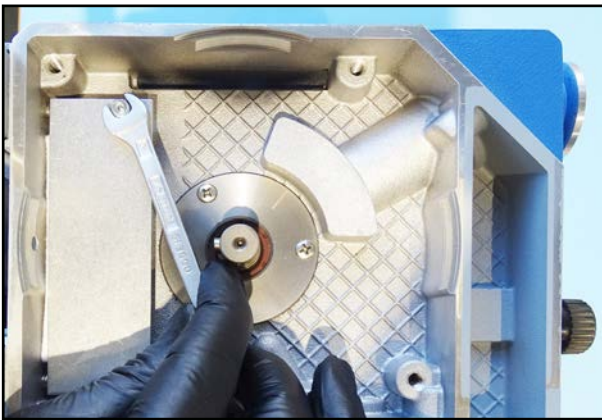

105. Screw the suction felt cover tight.

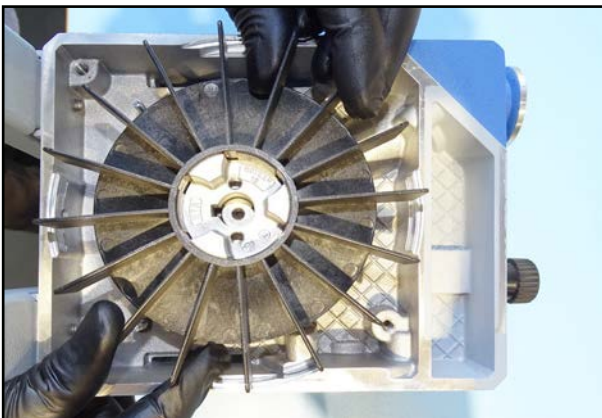

106. Insert the fan wheel with the coupling and push the fan wheel in as far as it will go.

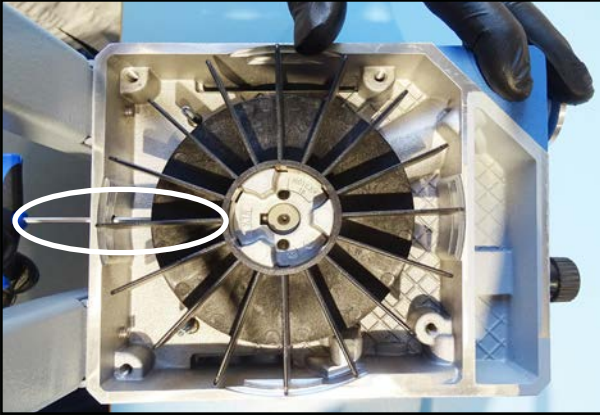

107. Tighten the fan wheel (grub screw in the coupling).

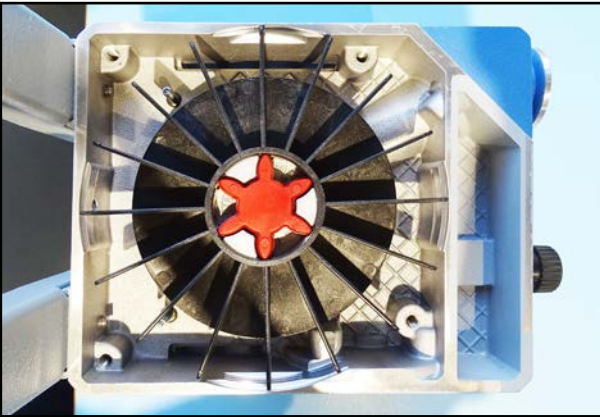

108. Insert the cross coupling.

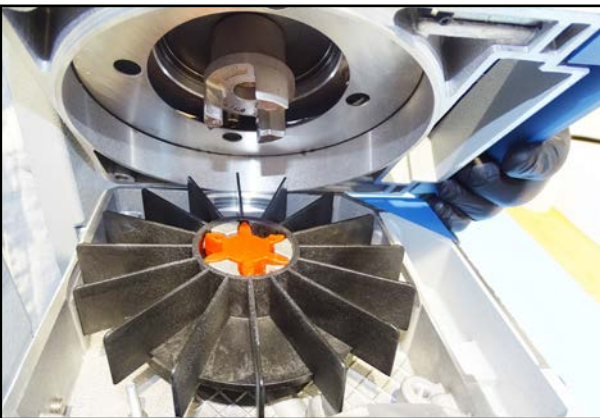

109. Carefully place the motor in the housing.



110. Screw the motor tight.
⇒ The terminal box of the motor must be aligned in the direction of the pump handle.
⇒ Recommended torque: 12 Nm.

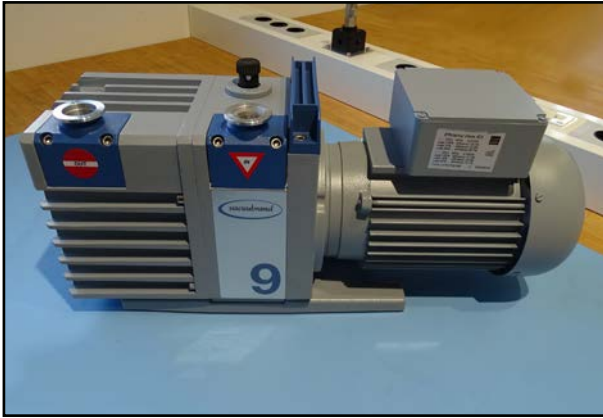

111. Place the pump on the pump feet.



112. Unscrew the small flange connections at the inlet and the outlet.

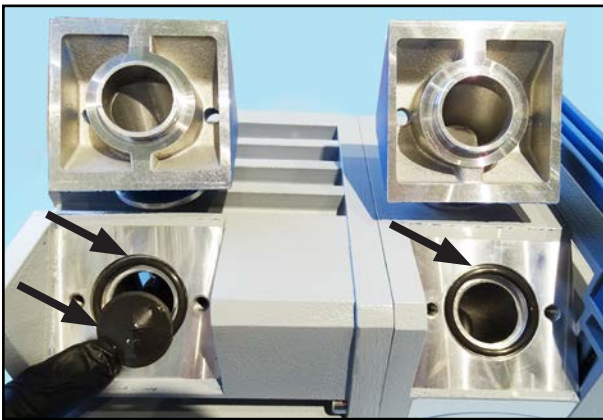

113. Replace the seals at the inlet and the outlet.

114. Replace the blind at the outlet.

115. Screw the inlet and the outlet tight.

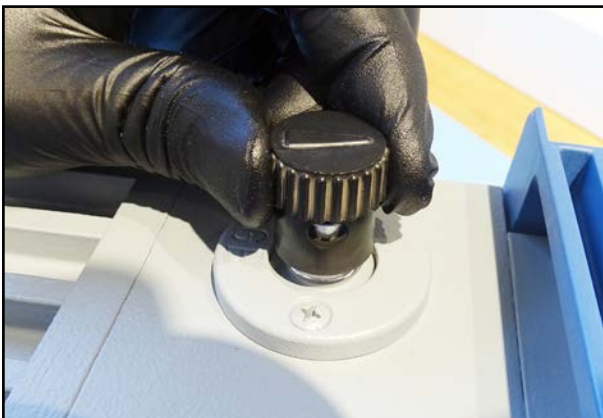

116. Remove the gas ballast cap.



117. Remove the insulating material from the gas ballast connection.

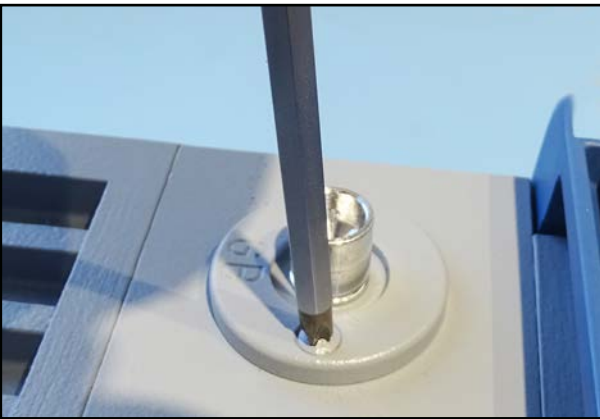

118. Unscrew the blind.



119. Remove the blind.



120. Remove the gas ballast connection.

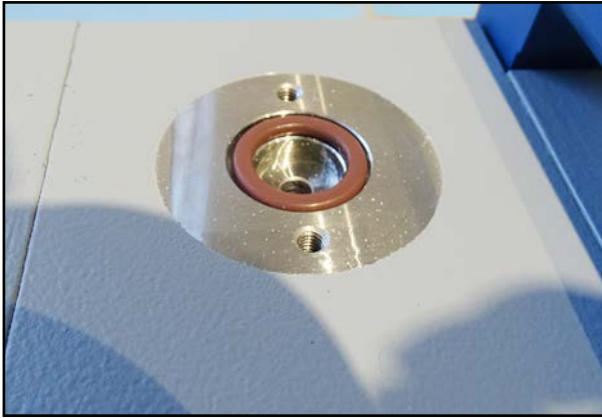

121. Replace the seal at the gas ballast connection.



122. Insert the gas ballast connection.

123. Obey the orientation of the gas ballast connection.

⇒ The hole must face outwards (facing away from the pump inlet).

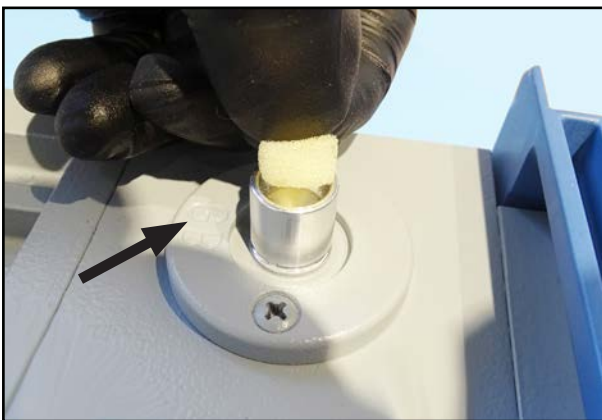

124. Screw the blind of the gas ballast connection tight.

⇒ The mark „GB“ on the blind must point in direction of the oil reservoir.

125. Insert new insulating material in the gas ballast connection.

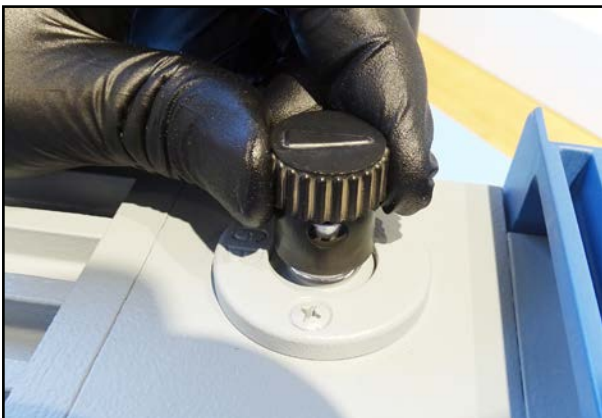

126. Insert the gas ballast cap.



127. Unscrew the oil inlet screw.
 128. Fill in oil.
 ⇒ The oil level must be between the „Min.“ and „Max.“ markings on the rating plate.



129. Screw in the oil inlet screw.



130. Let the pump run for approx. 1 hour with the outlet open, the gas ballast valve open and the inlet closed.



DANGER

Danger of electric shock.

Improperly executed repairs will result in an electrical shock.

- ⇒ Check the electrical safety of the device according to IEC 61010 and national regulations after repair.
- ⇒ Check the protective conductor resistance.
- ⇒ Check the insulation resistance.
- ⇒ Carry out a high voltage test.
- ⇒ Check the leakage current according to DIN EN 50678:2021 (EN 50678:2020) and national regulations.

5 Press-in mandrels

- ⇒ The press-in mandrels are designed for mounting shaft sealing rings in VACUUBRAND rotary vane pumps.
- ⇒ Shaft sealing rings should only be mounted with a special press-in mandrel.
- ⇒ Press only on the outer ring of the shaft seal.
- ⇒ When pressing in rotary shaft seals by means of a press-in mandrel, make sure that the mandrel can exit unhindered on the underside of the seal ring.

5.1 Selection of the press-in mandrel

Mandrel 3

Radial shaft seal 23120999 (25 x 32 x 4 mm) in bearing plate 20635415

Radial shaft seal 23120999 (25 x 32 x 4 mm) in bearing cover 20635421

6 Pull-off plate

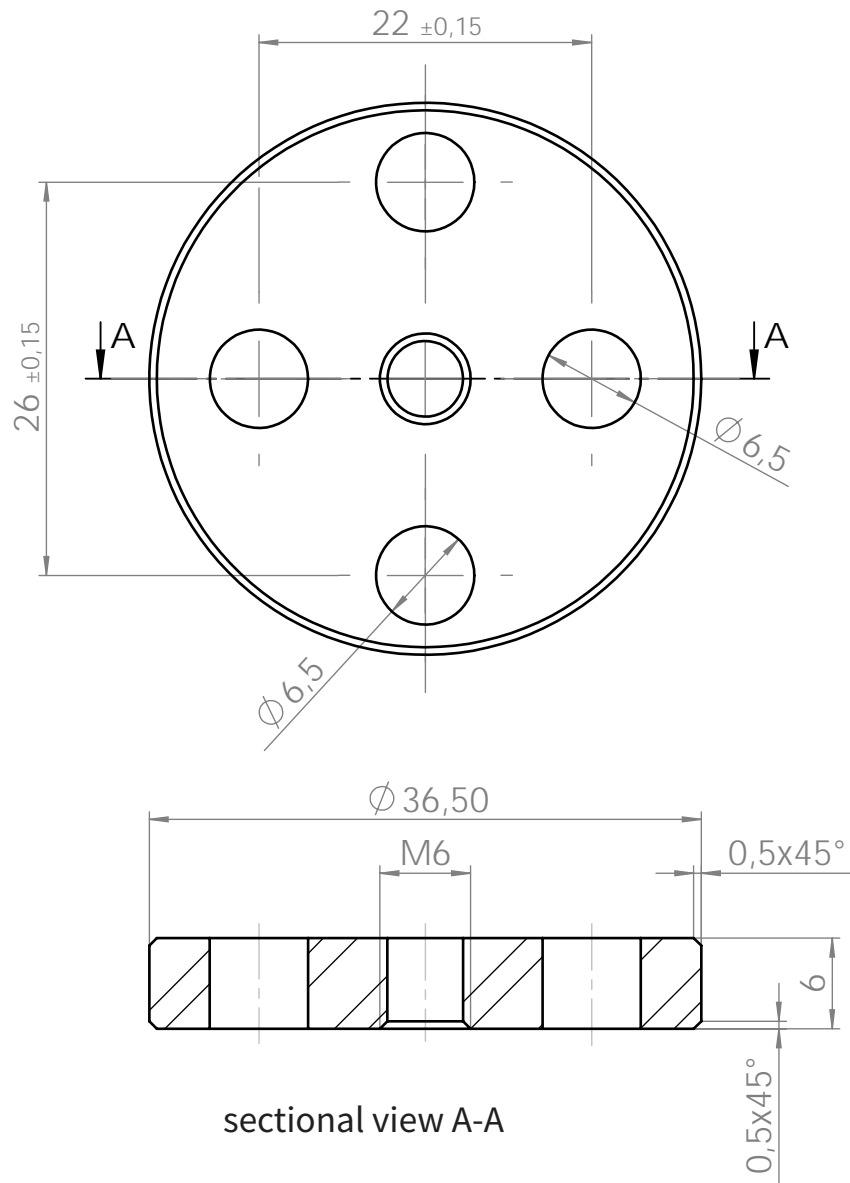

2 x cylinder screw M6x30

1 x wing screw M6x50

7 Exploded drawing RE 9

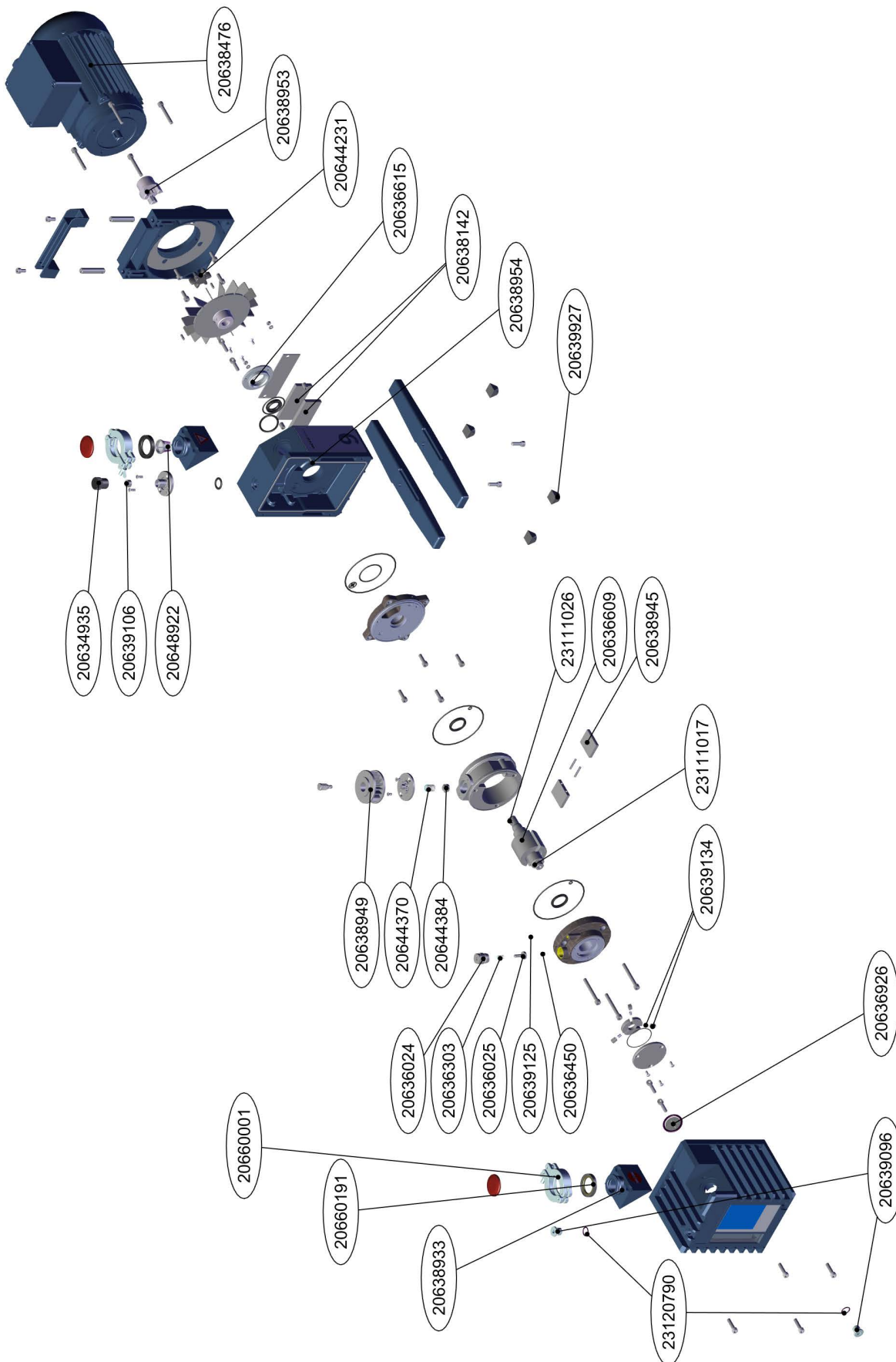

9 Spare parts

Order no.	Designation
20611210	Set of shaft seals RE/RZ 8/9/16
20634935	Gas ballast cap
20636024	Oil non-return valve housing
20636450	Oil non-return valve plate
20636609	Rotor D18 for RE 8 / 9
20636611	Rotor high vacuum stage D18 RZ 9
20636615	Shaft seal unit D18 for R 8 / R 9 / R 16, complete
20636926	Flow damper 0.8mm, outlet
20638142	Absorbent felt
20638476	Motor for R 9, 230 V/50-60 Hz
20638929	Pump assembly RE 9
20638933	Inlet- and outlet connection KF DN 25, R8 - R16
20638937	Pump assembly RZ 9
20638945	Vane L40
20638949	Oil separator R 8 / R 9 / R 16
20638954	Oil chamber gasket R 8 / 9 / 16
20638959	Rotor backing pressure stage RZ 8 / 9 / 16
20639096	Screw plug G1/4"
20639106	Rubber foam insert
20639125	Orifice 0.2mm
20639134	Set oil pump vanes with springs
20639927	Rubber foot
20644231	Insert for elastomer shaft coupling
20644370	Valve spring
20644384	Valve seat seal
20648922	Sieve unit (suction port) KF DN 25
20649988	Maintenance kit RE 8-RZ 16
20660001	Clamping ring, aluminum, KF DN 20/25
20660191	External centering ring, PBT, sealing ring NBR, KF DN 20/25
23111017	Shaft key, 4 x 4 x 8mm
23111026	Shaft key 5 x 5 x 16mm
23120790	O-ring, 13mm x 2mm, FPM

Other spare parts on request.

10 Service

Service range Take advantage of the comprehensive range of services available from **VACUUBRAND GMBH + CO KG**.

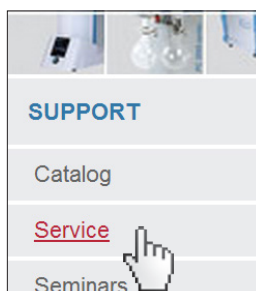

Services in detail

- Product consultation and practical solutions
- Fast delivery of spare parts and accessories
- Professional maintenance
- Immediate repairs processing
- On-site service (on request)
- With Health and Safety Clearance form: return, disposal.

⇒ Visit our website for further information: www.vacuubrand.com.

Service handling

⇒ Follow the description on: VACUUBRAND > Support > [Service](#)

Meet the terms of
service



Reduce downtime, speed up processing. Please have the required data and documents at hand when contacting our Service Department.

- ▶ Your order can be quickly and easily processed.
- ▶ Hazards can be prevented.
- ▶ A brief description and/or photos will help locate the source of the error.

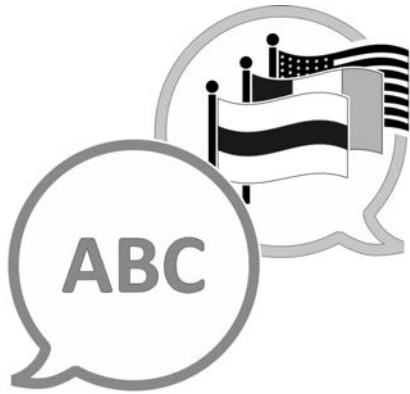

[VACUUBRAND > Support > Manuals](#)

Manufacturer:

VACUUBRAND GMBH + CO KG
Alfred-Zippe-Str. 4
97877 Wertheim
GERMANY

Phone:

Head office +49 9342 808-0
Sales +49 9342 808-5550
Service +49 9342 808-5660

Fax: +49 9342 808-5555

Email: info@vacuubrand.com

Web: www.vacuubrand.com